

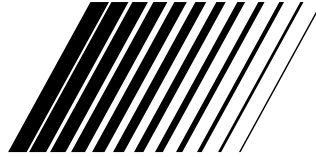

JVC



COMPACT VHS CAMCORDER

GR-AX760

Compact VHS



ENGLISH

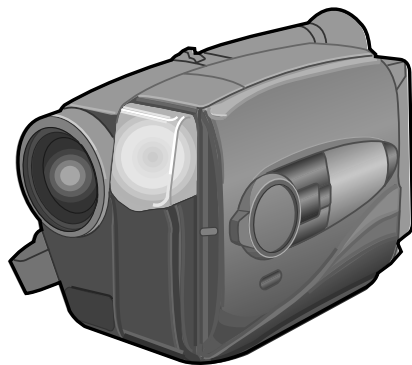

The Logical Choice



The only compact video cassettes that can be used with your VHS VCR*

*with Cassette Adapter

MAJOR FEATURES

- Program AE with Special Effects (☞ pgs. 22, 23)
- Digital Wipes and Fades (☞ pgs. 24, 25)
- Built-In Auto Light (☞ pg.15)
- Multi Function Control (☞ pg. 18 – 31)
- Digital Hyper Zoom (☞ pg. 13)
- Digital Image Stabilizer (☞ pg. 18)
- Random Assemble Editing (☞ pg. 36 – 39)

INSTRUCTIONS

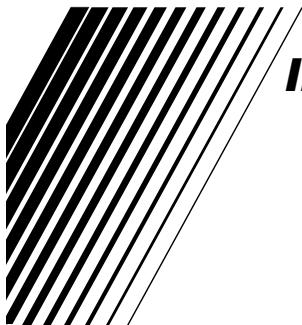

YU30052-583-1



2 EN

Dear Customer,

Thank you for purchasing the JVC Compact VHS camcorder. Before use, please read the safety information and precautions contained in the following pages to ensure safe use of your new camcorder.

Using This Instruction Manual

- All major sections and subsections are listed in the Table Of Contents (☞ pg. 3).
- Notes appear after most subsections. Be sure to read these as well.
- Basic and advanced features/operation are separated for easier reference.

It is recommended that you . . .

- refer to the Index (☞ pgs. 42 – 44) and familiarize yourself with button locations, etc. before use.
- read thoroughly the Safety Precautions that follow and cautions (☞ pgs. 45, 46). They contain extremely important information regarding the safe use of your new camcorder.

SAFETY PRECAUTIONS

WARNING:
TO PREVENT FIRE OR SHOCK HAZARD, DO NOT EXPOSE THIS UNIT TO RAIN OR MOISTURE.

CAUTIONS:

- To prevent shock, do not open the cabinet. No user serviceable parts inside. Refer servicing to qualified personnel.
- When you are not using the AC Power Adapter/Battery charger for a long period of time, it is recommended that you disconnect the power cord from AC outlet.

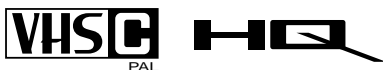

- Camcorder is designed exclusively for the VHS-C video cassette. Only cassettes marked VHS-C can be used with this unit.
- HQ VHS is compatible with existing VHS equipment.

Warning on lithium battery

The battery used in this device may present a fire or chemical burn hazard if mistreated. Do not recharge, disassemble, heat above 100°C or incinerate.

Replace battery with Panasonic (Matsushita Electric), Sanyo or Maxell CR2025; use of another battery may present a risk of fire or explosion.

- Dispose of used battery promptly.
- Keep away from children.
- Do not disassemble and do not dispose of in fire.

This camcorder is designed to be used with PAL-type colour television signals. It cannot be used for playback with a television of a different standard. However, live recording is possible anywhere. Use the BN-V12U/V22U/V25U battery packs and, to recharge them, the provided multi-voltage AC Power Adapter/Charger. (An appropriate conversion adapter may be necessary to accommodate different designs of AC outlets in different countries.)

NOTES:

- The rating plate (serial number plate) and safety caution are on the bottom and/or the back of the main unit.
- The rating plate (serial number plate) of the AC Power Adapter/Charger is on its bottom.







This unit is produced to comply with Standard IEC Publ. 65.

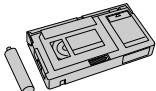
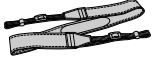

MAJOR FEATURES

- Program AE with Special Effects
(☞ pgs. 22, 23)
 - Cinema • Sepia • Twilight • Sports
 - High Speed (1/2000 sec.) Shutter
- Digital Wipes and Fades
(☞ pgs. 24, 25)
 - Black Fader • Blue Fader
 - Mosaic Fader • Shutter Wipe
 - Slide Wipe
- Built-In Auto Light (☞ pg.15)
- Multi Function Control
(☞ pg. 18 – 31)
- Digital Hyper Zoom (☞ pg. 13)
- Digital Image Stabilizer
(☞ pg. 18)
- Random Assemble Editing
(☞ pg. 36 – 39)

PROVIDED ACCESSORIES

- | | |
|---|---|
|  |  |
| • AC Power Adapter/
Charger AA-V11EG | • Battery Pack
BN-V12U |
|  |  |
| • Cassette Adapter C-P7U | • Shoulder Strap |
|  |  |
| • Lithium Battery
CR2025 x2 | • Cable adapter |
|  |  |
| • Editing cable | • Remote Control
Unit RM-V704U |
|  |  |
| • AUDIO/VIDEO
(A/V) cable | • DC Cord |

CONTENTS

EN 3

GETTING STARTED	4
Power	4
Clock (Lithium) Battery Removal/Insertion	6
Viewfinder Adjustment	6
Date/Time Setting	7
Tape Length Setting	8
Recording Mode Setting	9
Loading/Unloading A Cassette	9
Grip Adjustment	10
Shoulder Strap Attachment	10
Tripod Mounting	10
The RM-V704U Remote Control Unit	11
RECORDING	12
Basic Recording	12
Basic Features	13
Video Light	15
Advanced Features	16
Date/Time Insert	16
Quick Rec.	17
Digital Image Stabilizer (D.I.S.)	18
Exposure Control	18
White Balance Adjustment	19
Focusing	20
Program AE With Special Effects	22
Fade/Wipe	24
Using Menu For Detailed Adjustment.	26
Instant Titles	28
Self-Timer	30
Animation	31
Time Lapse	31
PLAYBACK	32
Using The Cassette Adapter	32
Basic Connections	33
Basic Playback	34
Features	35
EDITING	36
Tape Dubbing	36
Random Assemble Editing [R.A.Edit]	36
Insert Editing	40
Audio Dubbing	41
INDEX	42
Controls	42
Connectors	43
Indicators	43
Other Parts	43
Viewfinder	44
CAUTIONS	45
TROUBLESHOOTING	47
SPECIFICATIONS	49



Power

This camcorder's 3-way power supply system lets you choose the most appropriate source of power.

NOTES:

- No function is available without power supply.
- Use only specified power supply.
- Do not use provided power supply units with other equipment.

CHARGING THE BATTERY PACK

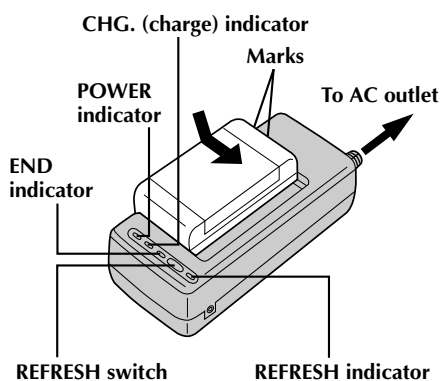

1 SUPPLY POWER

Connect the charger's AC power cord to a wall outlet. The power indicator lights.

2 ATTACH BATTERY PACK

Align the marks and slide the battery pack in the direction of the arrow until it locks in place. The CHG. indicator lights.

3 DETACH BATTERY PACK

When charging is completed, the END indicator lights. Slide the battery pack opposite the direction of the arrow.

BATT. PACK	CHARGE	DISCHARGE
BN-V12U	approx. 1 hr. 10 min.	approx. 3 hrs. 30 min.
BN-V22U	approx. 2 hrs. 10 min.	approx. 7 hrs.
BN-V25U	approx. 2 hrs. 40 min.	approx. 10 hrs.

USING THE BATTERY PACK

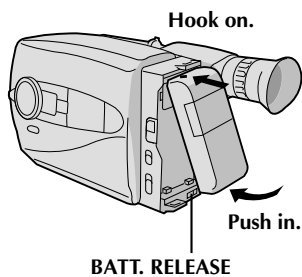

1 ATTACH BATTERY PACK

Hook its top end to the camcorder and push the battery pack in until it locks in place.

2 DETACH BATTERY PACK

Slide BATT. RELEASE and pull out the battery pack.

BATT. PACK	RECORDING TIME
BN-V12U	approx. 1 hr. 5min. (40 min.)
BN-V22U	approx. 2 hrs. 15 min. (1 hr. 25 min.)
BN-V25U	approx. 3 hrs. (1 hr. 50 min.)

() : When the Video Light is on

ATTENTION:

Before detaching the power source, make sure that the camcorder's power is turned off. Failure to do so can result in a camcorder malfunction.

**REFRESH

The AC power adapter features a REFRESH function that allows you to fully discharge the battery pack before recharging.

To discharge the battery . . .

..... attach the battery pack to the adapter as shown in the illustration to the left. Then push REFRESH. The REFRESH indicator lights when discharging starts, and goes out when discharging is complete.

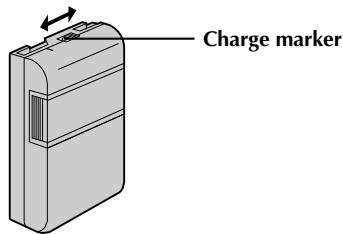

****CHARGE MARKER**

A charge marker is provided on the battery pack to help you remember whether it has been charged or not. Two colors are provided (red and black)—you choose which one means charged and which means discharged.

NOTES:

- The recording time per charge is affected by such factors as the time spent in Record/Standby mode and the frequency of zooming. It is safer to have spare battery packs.
- Charging times noted on page 4 are for fully discharged battery pack, and discharging times are for fully charged battery pack.
- Charging and discharging times vary according to the ambient temperature and the status of the battery pack.
- Remember to set the charge marker after charging a battery pack or after detaching a discharged one from your camcorder.
- Perform the REFRESH function after no less than 5 chargings.
- High temperatures can damage the battery pack, so use only where good ventilation is available. Don't allow it to discharge in container, such as a bag.
- If you stop recharging or discharging part way through, make sure to remove the battery pack before unplugging the adapter's AC cord.
- Remove the battery pack from the adapter immediately after discharging.
- To avoid interference with reception, do not use the AC Power Adapter/Charger near a radio.
- Make sure you unplug the DC cord before charging or discharging the battery pack.
- A blinking CHG. indicator means that the battery pack has become hot. Wait until it cools down to continue.
- The CHG. indicator may not light properly with a brand new battery pack, or with one that's been stored for an extended period. In this case, remove and reattach the battery pack and recharge it. The CHG. indicator should light during recharging. If not, contact your nearest JVC dealer.

USING A CAR BATTERY

Use the optional Car Battery Cord or Car Battery Charger/Adapter (connect as shown in the illustration to the left).

NOTES:

- When using the car battery, leave the engine idling.
- The optional Car Battery Charger (BH-V3E) can also be used to charge the battery pack.
- When using the optional Car Battery Charger or Car Battery Cord (AP-V7E), refer to the respective instruction booklet.

USING AC POWER

Use the AC Power Adapter (connect as shown in the illustration to the left).

NOTE:

The supplied AC Power Adapter/Charger features automatic voltage selection in the AC range from 110 V to 240 V.

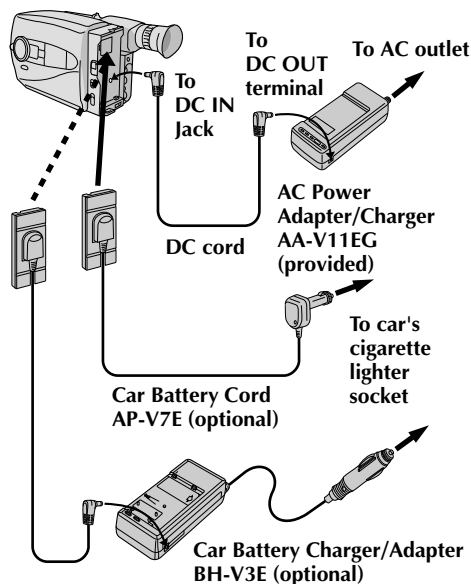



6_{EN}

GETTING STARTED (cont.)

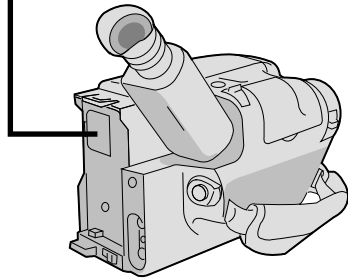
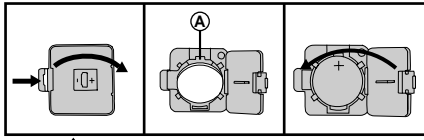

Clock (Lithium) Battery Insertion/Removal

This battery is necessary for clock operation and to perform date/time settings.

- 1 SWITCH OFF POWER**
Switch off the unit's power and remove the power supply unit.
- 2 OPEN COVER**
Open the clock battery compartment cover while pressing the release tab.
- 3 REMOVE BATTERY (when replacing)**
Insert a pointed, non-metallic object between the battery and the compartment (A) and pull the battery out.
- 4 INSERT BATTERY**
Ensuring the plus (+) side is up, insert the CR2025 lithium battery and push it in.
- 5 CLOSE COVER**
Close the compartment cover until it clicks in place.

NOTE:

See "SAFETY PRECAUTIONS" (pg. 2) for information on safe handling of lithium batteries.

Viewfinder Adjustment

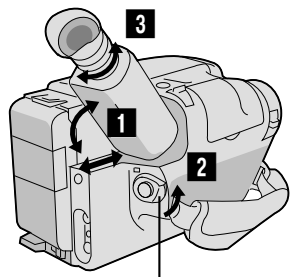

Set POWER to "CAMERA".

- 1 POSITION VIEWFINDER**
Adjust the viewfinder manually for best viewability (see illustration at left).
- 2 SELECT MODE**
Set the power switch to CAMERA.
- 3 ADJUST DIOPTR**
Turn the diopter adjustment control until the indications in the viewfinder are clearly focused.



Shooting mode selector

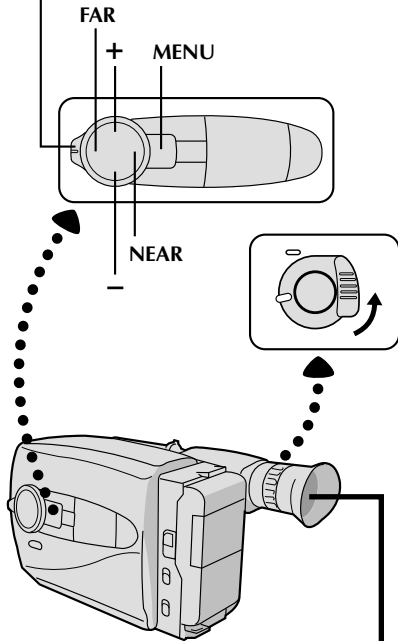

Main Menu Screen

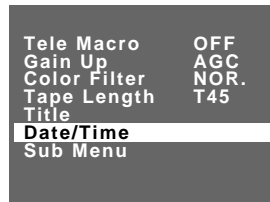

Set Time and Date Screen

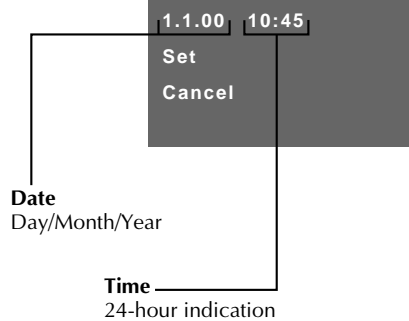

Date/Time Setting

- 1 SELECT MODE**
Set the Power switch to "CAMERA", and the Shooting Mode selector to "PRESET".
- 2 ACCESS MAIN MENU SCREEN**
Press MENU.
- 3 SELECT FUNCTION**
Press - to move the highlight bar down to "Date/Time", then press NEAR. The Set Date And Time screen appears.
- 4 SET DATE/TIME**
Press FAR or NEAR until the item you want to set begins blinking, then press + or - to until the correct setting appears.
 - If you decide you want to return the date and time to the previous settings, press FAR or NEAR to move the highlight bar to "Cancel", then press MENU.
 - If you're satisfied with the settings, go on to step 5.
- 5 START CLOCK OPERATION**
Once you've set the day, month, year and time, press FAR or NEAR until "Set" begins to blink, then press MENU. The Main Menu screen reappears.
- 6 CLOSE MAIN MENU**
Press MENU.

NOTES:

- To display the date and time in the viewfinder and on a connected TV, see "Date/Time Insert" (pg. 16).
- If, in step 4, you input an invalid date (30. 2., 31. 6., etc.) and perform step 5, "Input Error" appears blinking at the bottom of the screen. Press +, -, FAR or NEAR to input the correct number.



8 EN

GETTING STARTED (cont.)

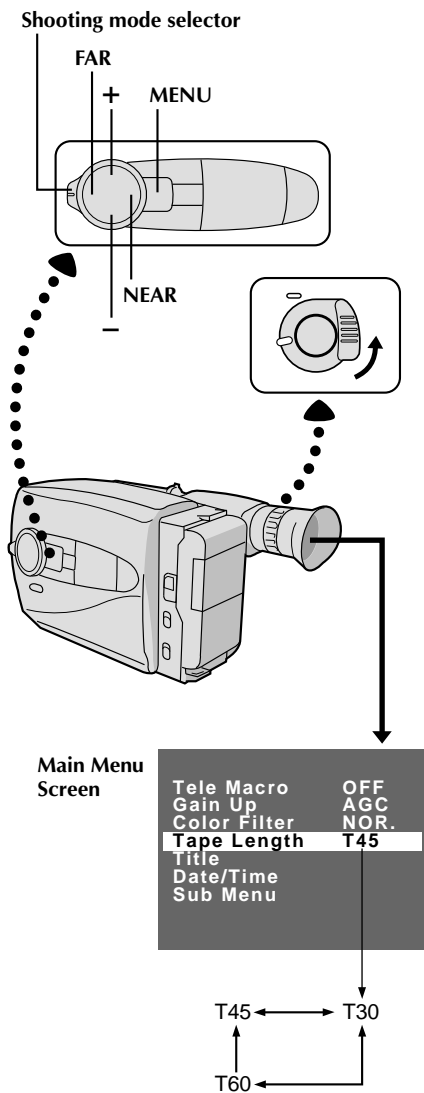

Tape Length Setting

- 1 SELECT MODE**
Set the Power switch to "CAMERA", and the Shooting Mode selector to "PRESET".
- 2 ACCESS MAIN MENU SCREEN**
Press MENU.
- 3 SELECT FUNCTION**
Press + or - to move the highlight bar to "Tape Length".
- 4 SET TAPE LENGTH**
Press FAR or NEAR to cycle through until the correct setting appears (depending on the tape used). T30 = 30 minutes of recording time, T45 = 45 min. and T60 = 60 min.
- 5 CLOSE MAIN MENU**
Press MENU.

NOTES:

- The tape remaining time (pg. 12) displayed in the viewfinder is correct only if the correct tape length has been selected.
- When using a 60-minute tape, the tape remaining time display will not be accurate.

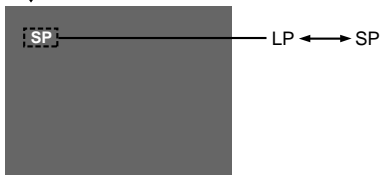
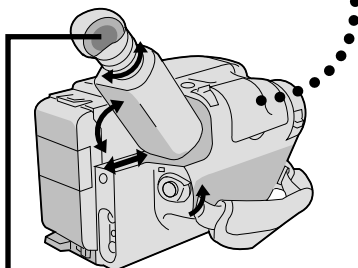
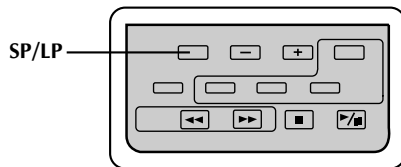

Recording Mode Setting

- 1 Pressing **SP/LP** alternates the setting between SP (standard play-provides higher picture and sound quality, better for dubbing) and LP (Long Play-more economical, recording at 1/2 the speed of SP).

NOTE:

If the recording mode is switched during recording, the playback picture will be blurred at the switching point.

Loading/Unloading A Cassette

- 1 **OPEN CASSETTE HOLDER**
Slide EJECT until the holder opens. Do not use force to open.
- 2 **INSERT/REMOVE CASSETTE**
Make sure the label is facing outward.
- 3 **CLOSE CASSETTE HOLDER**
Press PUSH and make sure the holder is closed and locked.

NOTES:

- A cassette holder can't be opened unless a power supply is attached.
- Make sure that the tape is not slack when loading the cassette. If there is any slack, turn the gear on the cassette in the direction of the arrow to take up the slack.
- Make sure the Erase Protection tab is present. If not, cover the hole with adhesive tape. (Some cassettes have sliding tabs – in this case, check the tab's position.)

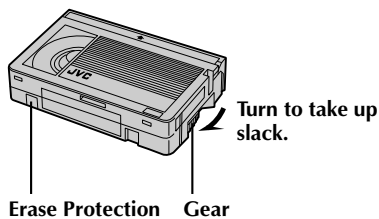
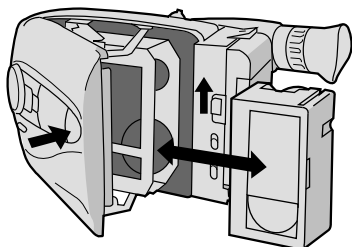

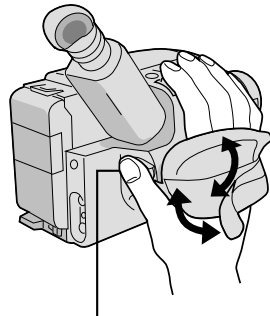

Recording Start/Stop button

Grip Adjustment

EXPAND LOOP

- 1 Separate the Velcro strip.

INSERT HAND

- 2 Pass your right hand through the loop and grasp the grip.

ADJUST STRAP LENGTH

- 3 Adjust so your thumb and fingers can easily operate the Recording Start/Stop button and Power Zoom lever. Refasten the Velcro strip.

Shoulder Strap Attachment

ATTACH STRAP

- 1 Following the illustration at left, thread the strap through the top of the eyelet ①, then fold it back and thread it through the keeper ②, and then through the buckle ③. Repeat the procedure to attach the other end of the strap to the other eyelet, making sure the strap isn't twisted.

ADJUST LENGTH

- 2 Adjust as shown in the illustration at left ①, then slide both keepers snug against the eyelets to prevent slipping ②.

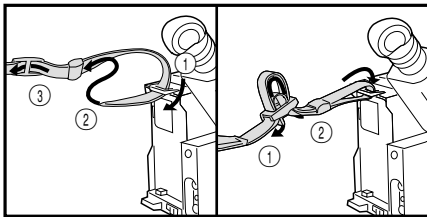

Tripod Mounting

ALIGN AND TIGHTEN

- 1 Align the screw and camera direction stud on the tripod with the camera's mounting socket and stud hole. Then tighten the screw.

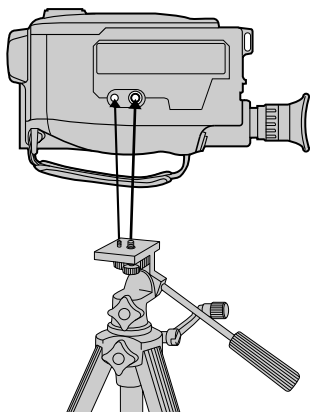

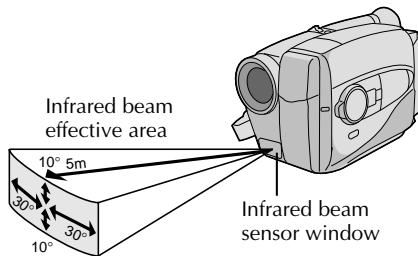

The transmitted beam may not be effective or may cause misoperations when the infrared beam sensor window is directly exposed to sunlight or powerful lighting.

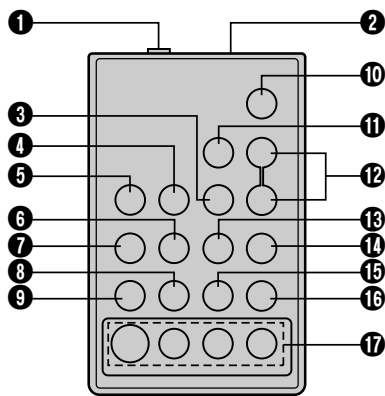

The RM-V704U Remote Control Unit

The RM-V704U Full-Function Remote Control Unit can operate this camcorder from a distance as well as the basic operations (PLAY, STOP, PAUSE, FF, and REW) of your VCR. This remote control unit makes additional recording functions possible. To operate, point it at the camcorder's remote sensor.

- 1 PULL OUT BATTERY HOLDER**
Pull out the battery holder according to the type of remote control unit you have.
Type **A**: Pull out the battery holder while sliding the lock hole.
Type **B**: Pinch the release tab and pull out the battery holder.
- 2 INSERT BATTERY**
Insert the lithium battery* (CR2025), with its plus (+) side up, into the battery holder.
- 3 REPLACE BATTERY HOLDER**
Replace the battery holder until it clicks in place.
*Read warning on lithium battery. (☞ pg. 2)

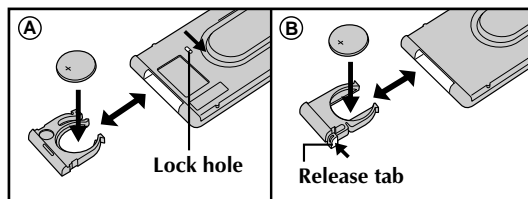

Buttons	Functions	
	With the camcorder's power switch set to "CAMERA".	With the camcorder's power switch set to "PLAY".
1 PAUSE IN connector	—	☞ pg. 38
2 Infrared beam transmitting window	Transmits the beam signal.	
3 MBR SET button	—	☞ pg. 37
4 INT. TIME button	Self-Timer/Time lapse (☞ pg. 30, 31)	—
5 REC TIME button	Animation/Time lapse (☞ pg. 31)	—
6 FF button	Retake (Forward) (☞ pg. 14)	FF/FF Shuttle Search (☞ pg. 34)
7 REW button	Retake (Rewind)/Quick Review (☞ pg. 13)	Rew/Rew Shuttle Search (☞ pg. 34)
8 PAUSE button	—	Pause/Play (☞ pg. 34)
9 PLAY button	—	Playback start (☞ pg. 34)
10 START/STOP button	Functions same as the Recording Start/Stop button of the camcorder.	
11 VISS button	Index code marking (☞ pg. 14)	—
12 ZOOM (T/W) button	Zoom in and out (☞ pg. 13)	—
13 VCR CTL button	—	☞ pg. 37
14 A. DUB button	—	Audio dubbing (☞ pg. 41)
15 STOP button	—	Stop (☞ pg. 34)
16 INSERT button	—	Insert Editing (☞ pg. 40)
17 R. A. EDIT button	—	☞ pg. 38

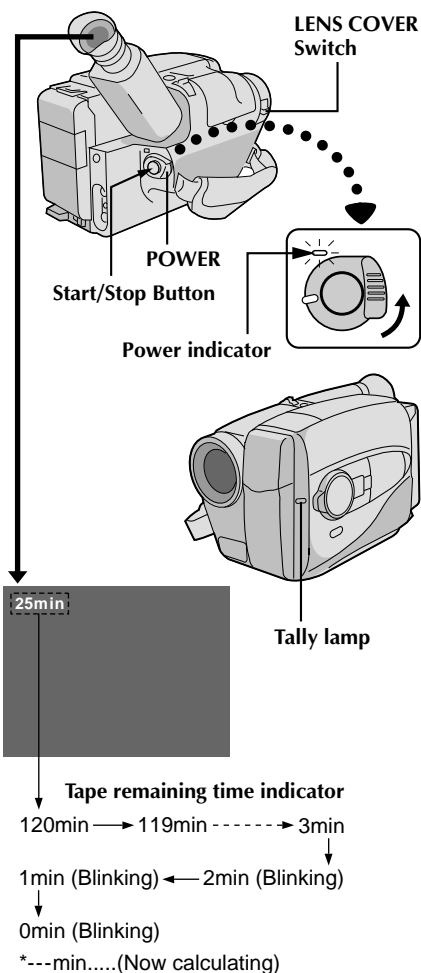
**NOTE:**

You should already have performed the procedures listed below. If not, do so before continuing.

- Power (☞ pg. 4)
- Tape Length (☞ pg. 8)
- Recording mode setting (☞ pg. 9)
- Grip Adjustment (☞ pg. 10)

LOAD A CASSETTE

- 1 Slide EJECT to open the cassette holder, then insert the cassette with the label facing out. Press PUSH to ensure the holder is closed and locked.

ENTER RECORD-STANDBY MODE

- 2 Slide the LENS COVER open/close switch to open the lens cover, then set the power switch to "CAMERA".

- The power indicator lights and the camcorder enters the Record-Standby Mode.
- The scene you're aimed at appears on the viewfinder screen, with the word "PAUSE" superimposed upon it.

START SHOOTING

- 3 Press the Recording Start/Stop button.

- The tally lamp lights while recording is in progress, and "REC" appears in the viewfinder.
- If you want to turn the tally lamp off, see page 27.

STOP RECORDING

- 4 Press the Recording Start/Stop button again to stop recording.

- The camcorder re-enters the Record-Standby mode.

NOTES:

- A cassette holder can't be opened unless a power supply is attached.
- There may be a delay after you slide EJECT until the holder opens. Do not use force.
- The tape's remaining time is displayed in the viewfinder as shown.
- The indicated remaining time is approximate.
- The time required to calculate the remaining tape length, and the accuracy of the calculation, may vary according to the type of tape used.
- The tape remaining time displayed in the viewfinder is correct only if the correct tape length has been selected (☞ pg. 8).
- When using a 60-minute tape, the tape remaining time display will not be accurate.
- "TAPE END" appears when the tape reaches its end, and the power goes off automatically if left in this condition for 5 minutes. "TAPE END" also appears when a cassette whose tape is already at its end is loaded.
- If the Record-Standby mode continues for 5 minutes without performing Zoom or any other operations, the camcorder's power shuts off automatically. Set the Power switch to "POWER OFF", and then back to "CAMERA" to turn the camcorder on again.
- If you're recording on a cassette from the middle, use the RETAKE function (☞ pg. 14) to find the end of the last recording so you don't erase any of it.
- The LENS COVER warning blinks for about 8 seconds when the camcorder is turned on, when the cover is closed.



RECORDING Basic Features

EN 13

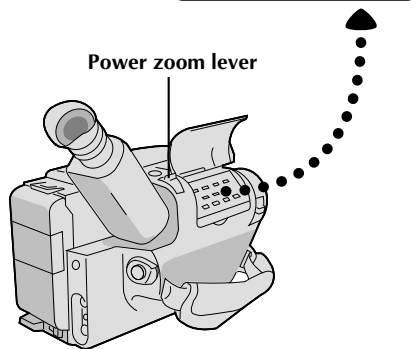
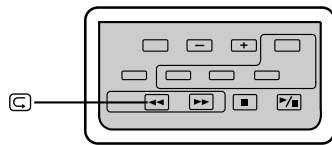
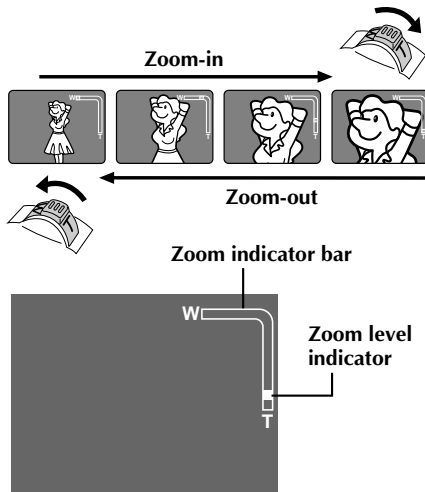

<p>FEATURE:</p> <p>PURPOSE:</p> <p>OPERATION:</p> <p>NOTES:</p>	<p>Zooming</p> <p>To produce the zoom in/out effect, or an instantaneous change in image magnification.</p> <p>28X Hyper zoom</p> <p>Digital circuitry doubles the maximum 14x magnification offered by optical zoom.</p> <p>1) To zoom in, slide the Zoom Lever toward "T".</p> <p>2) To zoom out, slide toward "W".</p> <ul style="list-style-type: none"> • During Hyper Zoom, the speed increases the further you slide the Zoom Lever. • Focusing may become unstable during Hyper Zoom. In this case, set the zoom while in Record – Standby, set manual focus or Focus Lock (☞ pgs. 20, 21), then zoom in or out in Record mode. • The Zoom Level Indicator (■) only moves during optical zoom. Once the indicator reaches "T", all magnification from that point is through digital processing. • During digital image processing, the quality of the image may suffer.
<p>FEATURE:</p> <p>PURPOSE:</p> <p>OPERATION:</p> <p>NOTE:</p>	<p>Quick Review</p> <p>To check the end of the last recording.</p> <p>1) Press "☐" and release quickly during the Record–Standby mode</p> <ul style="list-style-type: none"> • Tape is rewound for about 2 seconds and played back automatically, then pauses in Record–Standby mode for the next shot. <p><i>Distortion may occur at start of playback. This is normal.</i></p>

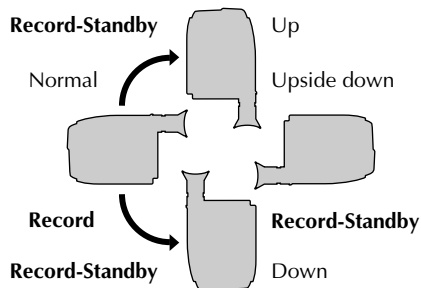
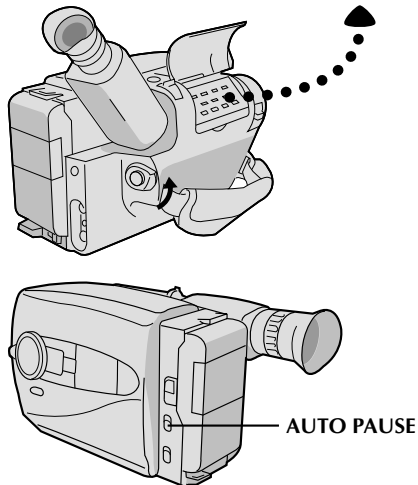
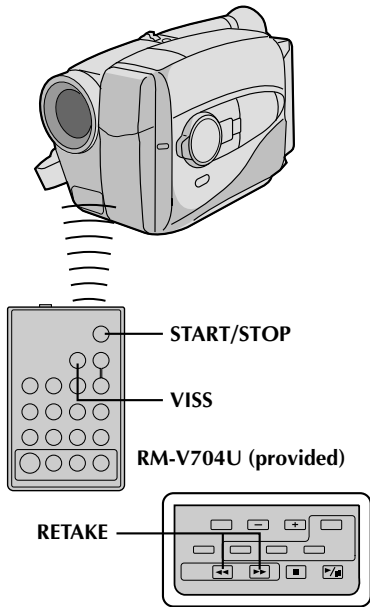

<p>FEATURE: PURPOSE:</p> <p>OPERATION:</p> <p>NOTE:</p>	<p>Index Code Marking To give you automatic access to any selected point on a recording. Auto Marking and Manual Marking are available.</p> <p><i>Auto Marking</i> An index code is marked to start the first recording after a cassette is inserted, as long as the Power switch is set to "CAMERA".</p> <p><i>Manual Marking</i> 1) Press VISS once to place the index code. INDEX blinks in the viewfinder during marking.</p> <p><i>If VISS is pressed during Record-Standby mode, the mark is placed where the Recording Start/Stop button is pressed.</i></p>
<p>FEATURE: PURPOSE: OPERATION:</p> <p>NOTE:</p>	<p>Retake To re-record certain segments.</p> <p>1) Make sure the camcorder is in the Record-Standby mode. 2) Press either RETAKE button to reach the start point for new recording. 3) Press the Recording Start/Stop button to start recording.</p> <p><i>Noise may appear during Retake. This is normal.</i></p>
<p>FEATURE: PURPOSE:</p> <p>OPERATION:</p> <p>NOTES:</p>	<p>Auto Pause System To automatically stop recording when the camcorder is pointed down, preventing accidental recordings of the ground, your feet, etc.</p> <p>1) Set AUTO PAUSE to "ON". When the camcorder is tilted down by a large degree from its horizontal position during recording, the Record-Standby mode is automatically engaged. "AUTO PAUSE" appears in the viewfinder.</p> <ul style="list-style-type: none"> • The Auto Pause System is also effective when the camcorder is pointed up, or is positioned upside down. • Auto Pause also works when the camcorder is twisted by a large degree to the left or right. • When you want to shoot in any of the aforementioned positions, make sure you set AUTO PAUSE to "OFF".

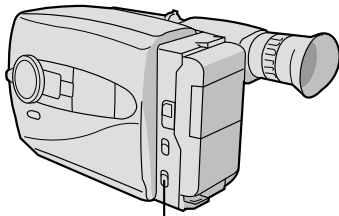

LIGHT ON/AUTO/OFF

Video Light

When natural lighting is too dim, you can brighten the scene by using the built-in video light.

SET VIDEO LIGHT

1 Set the **LIGHT ON/AUTO/OFF** as required.

- ON** : Always keeps the light on as long as the camcorder is turned on.
- AUTO** : Automatically turns on the light when the camcorder senses insufficient lighting on the subject.
- OFF** : Turns off the light.

- The video light can be used with the camcorder's power on.
- It is recommended to set the white balance (☞ pg. 19) to indoor mode (☞) when you use the video light.
- When not using the video light, turn it off to save battery power.

NOTES:

- Even if the battery indicator (☐) does not blink in the viewfinder, if the battery pack's charge is low, the camcorder may turn off automatically when you turn on the video light, or when you start recording with the video light turned on.
- When the **LIGHT ON/AUTO/OFF** switch is set to "AUTO":
 - Depending on the lighting conditions, the video light may keep turning on and off. In this case, manually switch the light on or off using the **LIGHT ON/AUTO/OFF** switch.
 - While the Sports or High-Speed Shutter mode (☞ pg. 23) is engaged, the light is likely to stay on.
 - While the Twilight mode (☞ pg. 23) is engaged, the light will not activate.

DANGER

- The video light become extremely hot. Do not touch it either while in operation or soon after turning it off, otherwise serious injury may result.
- Do not place the camcorder into the carrying case immediately after using the video light, since it remains extremely hot.
- When operating, keep a distance of about 30 cm. (between the video light and people or objects).
- Do not use near flammable or explosive materials.
- It is recommended that you consult your nearest JVC dealer for replacing the video light.



16_{EN}

RECORDING Advanced Features

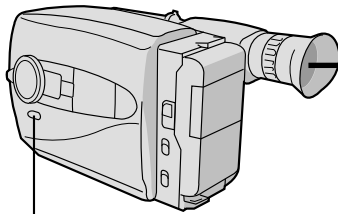

DISPLAY

Date/Time Insert

This feature allows you to display the date and time in your viewfinder and on a connected TV.

NOTE:

You should already have performed the Date/Time Setting procedure (☞ pg. 7). If you haven't, do so before continuing.

DISPLAY

1 CHOOSE DISPLAY MODE

1 Press **DISPLAY** during Record-Standby to cycle through the available modes as shown in the illustration at left.

NOTES:

- The selected display can be recorded.
- If you don't want to record the display, select Date-off mode before shooting.
- If you want to delete the display during shooting, press **DISPLAY**.
- If you want to call back a deleted display, engage the Record-Standby mode and then press **DISPLAY** to select the desired display mode.

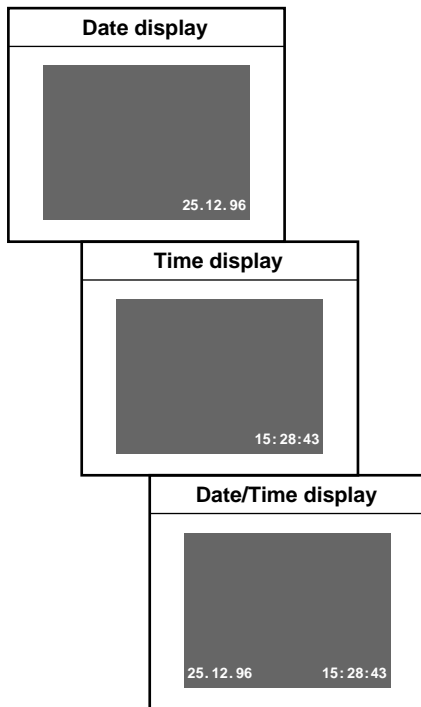
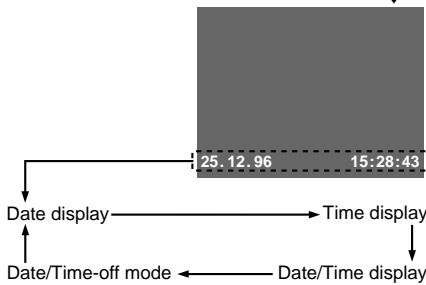



QUICK REC

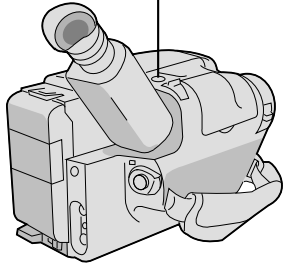

Quick Rec

Records a scene for 5 seconds, providing quick scene transitions like those seen in TV programmes.

1 During Record-Standby, press and release **QUICK REC**. Recording starts, and after 5-second recording is finished, the camcorder reenters the Record-Standby mode automatically.

- To continue shooting longer than 5 seconds, press and hold **QUICK REC**. Recording continues as long as **QUICK REC** is kept pressed.

NOTES:

- The Fade/Wipe (☞ pg. 24) cannot be activated by pressing **QUICK REC**.
- **QUICK REC** cannot be used during Animation (☞ pg. 31) and Time-Lapse (☞ pg. 31).



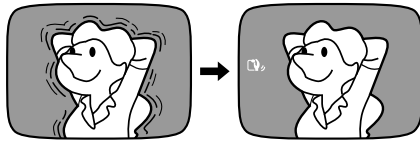

Digital Image Stabilizer

This feature compensates for unstable images caused by camera-shake, particularly noticeable at high magnification.

- 1 ACTIVATE D. I. STABILIZER**
Press **D.I.STABILIZER**. "D.I.S." appears in the viewfinder.
• To switch off the Digital Image Stabilizer, press **D.I.STABILIZER**. The indicator disappears.

NOTES:

- Accurate stabilization may not be possible if hand shake is excessive, or under the following conditions:
 - When shooting subjects with vertical or horizontal stripes
 - When shooting dark or dim subjects
 - When shooting subjects with excessive backlighting
 - When shooting scenes with movement in various directions
 - When shooting scenes with low-contrast backgrounds
- Switch off D.I.STABILIZER when recording with the camcorder on a tripod.

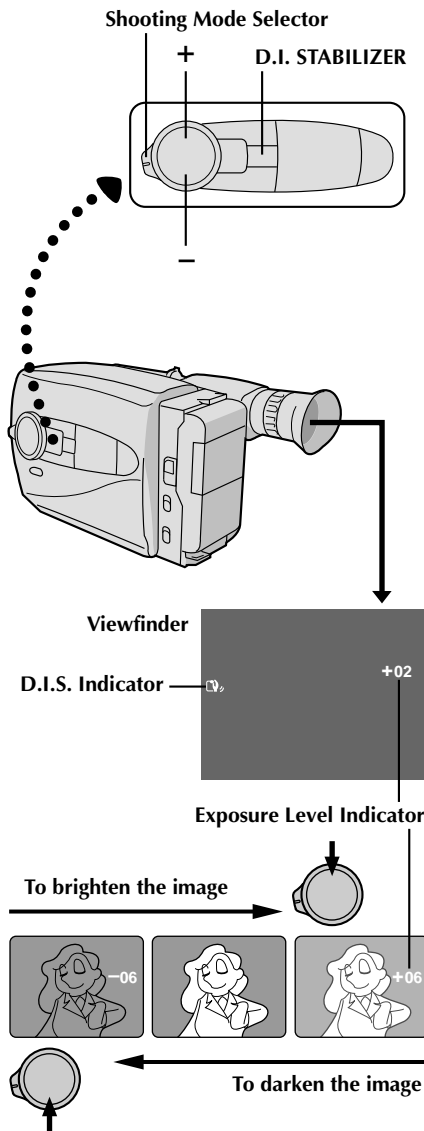

Exposure Control

This feature automatically adjusts the iris for the best available picture quality, but you can override and make the adjustment manually.

- 1 SELECT SHOOTING MODE**
Set the Shooting Mode selector to "PRESET".
- 2 BRIGHTEN IMAGE**
Press + (maximum +06). The Exposure level indicator appears in the viewfinder.
OR . . .
DARKEN IMAGE
Press - (maximum -06). The Exposure level indicator appears in the viewfinder.
When you want to return to the factory setting . . .
- 3 RESTORE INITIAL SETTING**
Press + and - simultaneously. The standard setting is immediately restored and the Exposure level indicator disappears.

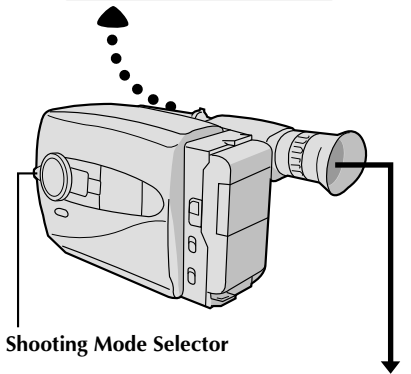
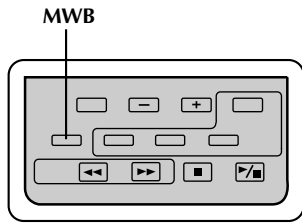

Shooting Mode Selector

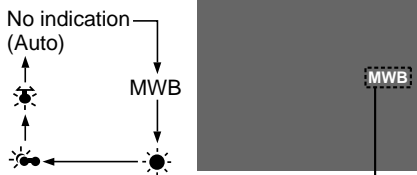

White balance mode indicator

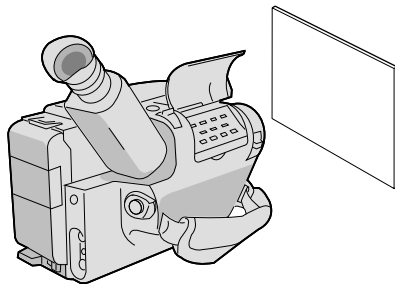

White Balance Adjustment

This camcorder's Automatic Colour Temperature system senses the colour temperature of the ambient lighting for automatic white balance adjustment. However, precise colour adjustment is not possible under the following conditions:

- When an object is in various shades of the same colour.
- When a predominantly red or brown object is being shot outdoors.

In these cases, use the camcorder's built-in preset filters for white balance adjustment.

SELECT SHOOTING MODE

- 1 Set the Shooting Mode selector to "PRESET".

SELECT FUNCTION

- 2 Press **MWB** (Manual White Balance) until the required indication appears in the viewfinder.

- "MWB" With a memorized personal White Balance setting (see below)
- "☀" Outdoors on sunny day
- "☁" Outdoors on cloudy day
- "💡" Light source is halogen or tungsten lamp

MWB sets the colour temperature for the subject's light source so you can shoot with natural colours that are unaffected by surroundings, even when there are multiple subjects with different colour temperatures.

SELECT SHOOTING MODE

- 1 Set the Shooting Mode selector to "PRESET".

ADJUST FOCUS

- 2 Point the camcorder at a white, flat object such as a sheet of white paper, and adjust focus manually (☞ pg. 21).

ADJUST WHITE BALANCE

- 3 Press **MWB** until "MWB" appears, then press and hold **MWB** for more than 3 seconds.

- "MWB" blinks in the viewfinder during adjustment, then stops blinking but stays lit when adjustment is complete.

NOTES:

- To switch to automatic white balance adjustment, press **MWB** until the indication disappears, or turn the Shooting Mode selector to "FULL AUTO".
- Re-adjust the White Balance mode when the lighting has changed, when the camcorder has been turned on and off again, or when the Shooting Mode selector's position has been changed.
- It is helpful to connect your camcorder to a colour monitor when adjusting the white balance ("Basic Connections" ☞ pg. 33).
- When adjusted by putting coloured paper in front of the subject in step 2 ("ADJUST FOCUS"), this unit makes its colour temperature standard for automatic white balance. So you can enjoy shooting with different colours. For example, when adjusting with red, blue or yellow colours, the image becomes the colour which approximates to green, orange or purple respectively.

Focus
detection zone

Shooting mode selector

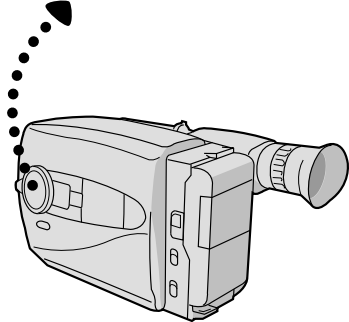
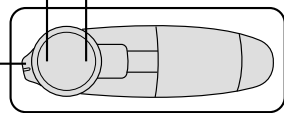
FAR
NEAR

Focusing

Auto Focus

The camcorder's Full Range AF system offers continuous shooting ability from close-up to infinity. However, correct focus may not be obtainable in the situations listed below (in these cases use manual focusing):

- When two subjects overlap in the same scene.
- When illumination is low.*
- When the subject has no contrast (difference in brightness and darkness), such as a flat, one-colour wall, or a clear, blue sky.*
- When a dark object is barely visible in the viewfinder.*
- When the scene contains minute patterns or identical patterns that are regularly repeated.
- When the scene is affected by sunbeams or light reflecting off the surface of a body of water.
- When shooting a scene with a high-contrast background.

* The low-contrast warning "▲▲" appears in the viewfinder.

Focus Lock

This feature locks the focus in place, which is especially helpful in the following situations:

- When things pass between your subject and the camcorder. Engage the focus lock function to lock your subject in before recording.
- When you want your subject to be focused, and to appear in a corner of the screen. First, centre on the subject and focus using auto focus mode. Then engage the focus lock function and move the camcorder until the subject is where you want it.

1 SELECT SHOOTING MODE

Set the Shooting Mode selector to "PRESET".

2 LOCK FOCUS

Press **FAR** or **NEAR**. The focus lock indication "▲▲" appears in the viewfinder.

3 RELEASE FOCUS LOCK

Press **FAR** and **NEAR** simultaneously. The focus lock indication disappears.

NOTES:

- If the lens is smeared or blurred, accurate focusing is not possible. Keep the lens clean, wiping with a piece of soft cloth if it gets dirty. When condensation occurs, wipe with a soft cloth or wait for it to dry naturally.
- When shooting a subject close to the lens, zoom-out first (☞ pg. 13). If zoomed-in in the auto focus mode, the camcorder could automatically zoom out depending on the distance between the camcorder and the subject. *When Tele Macro is activated, the camcorder will not zoom out automatically.



Shooting mode selector

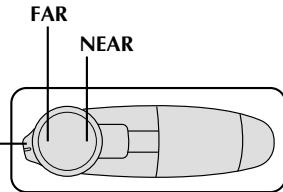

Power zoom lever

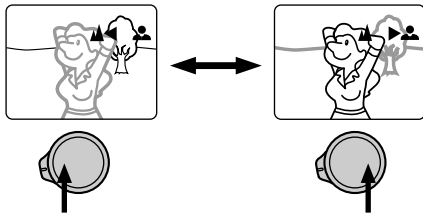
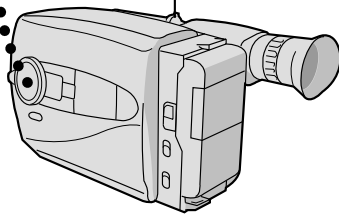

Manual Focus

NOTE:

You should already have made the necessary viewfinder adjustments (pg. 6). If you haven't, do so before continuing.

1 SELECT SHOOTING MODE

Set the Shooting Mode selector to "PRESET".

2 ADJUST FOCUS

A TO FARTHER SUBJECT

Press and hold **FAR**. The Manual Focus indications "▲▲" appear and "◀" blinks. Go to step 3.

B TO NEARER SUBJECT

Press and hold **NEAR**. The Manual Focus indications "▲▶" appear and "▶" blinks. Go to step 3.

3 LOCK FOCUS

Release **FAR** or **NEAR**. The focus indication is replaced by the focus lock indication "▲▲" and the adjusted focus is locked in.

4 RELEASE MANUAL FOCUS MODE

Press **FAR** and **NEAR** simultaneously. The Manual Focus mode is immediately released and the focus lock indication disappears.

NOTES:

- Be sure to focus the lens in the maximum telephoto position when you use the Manual Focus mode. If you focus in on a certain subject in the wide-angle position, sharply focused images cannot be obtained when zoomed up because the depth-of-field is reduced at longer focal lengths.
- When the focus level cannot be adjusted any farther or closer, "▲" or "▶" will blink.



Shooting Mode Selector

EFFECT/PROG.AE

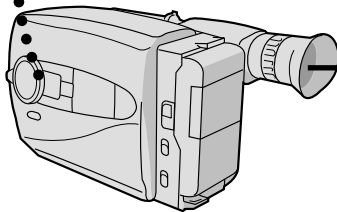
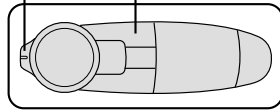

Effect menu



EFFECT/PROG.AE indicator

Program AE With Special Effects

Useful in making the picture look creative and attractive. Effects can be selected during recording, as well as in Record-Standby.

- 1 SELECT SHOOTING MODE**
Set the Shooting Mode selector to either "FULL AUTO" or "PRESET".
If you set to "FULL AUTO",...
.... only the Cinema mode can be activated.
If you set to "PRESET",...
.... you can choose any one of the 5 effects available.





- 2 SELECT EFFECT**
If you set to "FULL AUTO",...
.... pressing EFFECT/PROG.AE turns the Cinema mode on and off.
If you set to "PRESET",...
.... pressing EFFECT/PROG.AE brings up the Effect menu. Press again to move the highlight bar to the desired effect. Once you decide on an effect, it is selected and activated, and its indicator appears, within 2 seconds.

• If you started this procedure in the Record-Standby mode, press the Recording Start/Stop button to begin recording at this point.

- 3 DEACTIVATE EFFECT**
When the Shooting Mode Selector is set to "FULL AUTO",...
.... press EFFECT/PROG.AE.
When set to "PRESET",...
.... press EFFECT/PROG.AE to bring up the Effect Menu, and press again to move the highlight bar to "OFF".





INDICATION	MODE	EFFECT
	CINEMA	Adds black bars to the top and bottom of the screen to produce a cinema-like "16:9 wide-screen" effect.
	SEPIA	The picture becomes sepia-tinted (reddish brown) monochrome, creating the look of an old photograph.
	TWILIGHT	Makes dusk and twilight scenes, etc. look more natural and dramatic. White balance is set to "☀️". Press MWB if you want to change the setting.
	SPORTS	Automatically adjusts to high shutter speed (1/250 to 1/500) to clearly capture fast-moving action with less blur. Clarity is especially noticeable during slow motion or still playback on a VCR. Great for sports, races, etc.
	HI-SPEED SHUTTER (1/2000)	Captures even faster action than Sports effect.

NOTES:

- When the Sepia effect is activated, pressing MWB (white balance) has no effect.
- Certain effects cannot be used together with other functions. When an effect not usable in the present situation is selected, its indicator blinks.

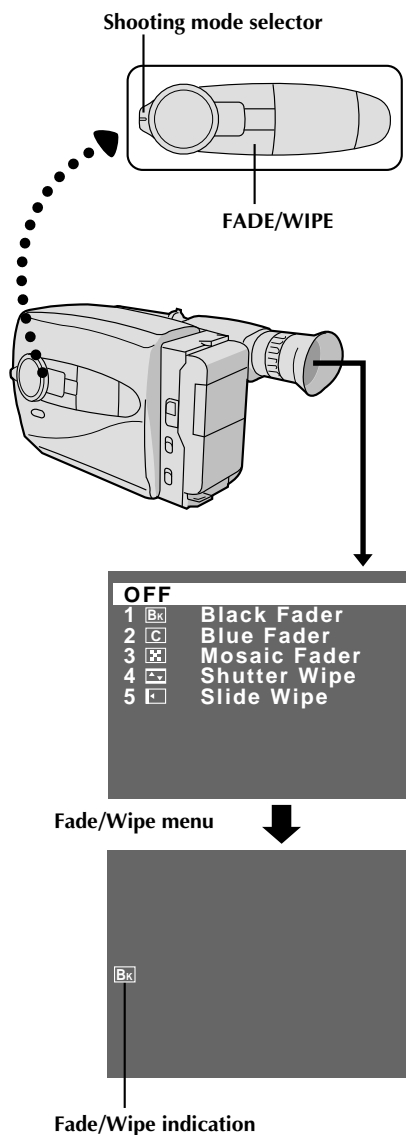

Fade/Wipe

These effects let you make pro-style scene transitions.

1 SELECT SHOOTING MODE

Set the Shooting Mode selector to either "FULL AUTO" or "PRESET".

If you set to "FULL AUTO", . . .

.... only the Black Fader mode is available.

If you set to "PRESET", . . .

.... you can choose any one of the effects available.

2 RESERVE EFFECT

If you set to "FULL AUTO", . . .

.... pressing FADE/WIPE turns the Black Fader mode on and off.

If you set to "PRESET", . . .

.... pressing FADE/WIPE brings up the Fade/Wipe menu. Press again to move the highlight bar to the desired effect. Once you decide on an effect, it is selected and reserved, and its indicator appears, within 2 seconds.

3 START RECORDING

Press the Recording Start/Stop button to start recording and activate a fade- or wipe-in.

OR . . .

END RECORDING

Press the Recording Start/Stop button to stop recording and engage a fade- or wipe-out.

4 DEACTIVATE EFFECT

When the Shooting Mode Selector is set to "FULL AUTO", . . .

.... press FADE/WIPE.

When set to "PRESET", . . .

.... press FADE/WIPE to bring up the Fade/Wipe menu, then press again to move the highlight bar to "OFF".

NOTE:

When the Shooting Mode selector is set to "FULL AUTO", after a fade-in, Black Fader is no longer reserved. To reserve it for a fade-out, press FADE/WIPE. "[Bk]" appears in the viewfinder.



EN 25



BLACK FADER

Fades in/out to a black screen.



BLUE FADER

Fades in/out to a blue screen.



MOSAIC FADER

Gradually turns/returns the picture into/from a mosaic pattern.



SHUTTER WIPE

A black screen moves in from the top and bottom, closing over the image like a shutter, or a new image pushes open the black screen vertically from the centre.



SLIDE WIPE

A black screen moves in from the left to gradually cover the image, or a new image moves in from right to left.





Shooting mode selector

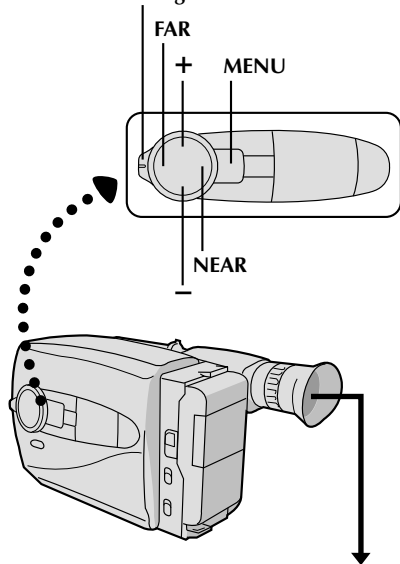

Tele Macro	OFF
Gain Up	AGC
Color Filter	NOR.
Tape Length	T45
Title	
Date/Time	
Sub Menu	

Main Menu screen

Tally	ON
Interval Timer	OFF
Rec Time	OFF
JLIP ID NO.	07

Sub Menu screen

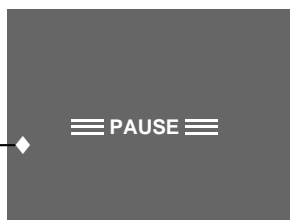

If any settings in the Main Menu have been changed from the factory settings, this mark appears in the viewfinder.

Using Menu For Detailed Adjustment

This camcorder is equipped with Multi-Function Control, an easy-to-use, on-screen menu system that simplifies many of the more detailed camcorder settings.

1 SELECT SHOOTING MODE

Set the Shooting Mode selector to "PRESET".

2 ACCESS MAIN MENU SCREEN

Press MENU.

3 SELECT FUNCTION

Press + or - to place the highlight bar on the desired function.

4 MAKE SETTING

The setting procedure depends on the function you select.

If you select "Tele Macro", "Gain Up", "Color Filter" or "Tape Length", . . .

.... press FAR or NEAR to cycle through the choices until the desired setting appears. Then go to step 8.

If you select "Title" or "Date/Time", . . .

.... press NEAR to access the selection menu for each function (Title – pg. 28; Date/Time – pg. 7).

If you select "Sub Menu", . . .

.... press NEAR to bring up the Sub Menu screen. Go to step 5.

5 SELECT FUNCTION AT SUB MENU

Press + or - to place the highlight bar on the desired option, then press NEAR. The selected item begins blinking.

6 CHANGE SETTINGS

Press + or - to change the displayed setting of the selected function, then press FAR to enter your choice. The selected item stops blinking.

7 CLOSE SUB MENU

Press FAR, and setting is complete. The Sub menu screen disappears and the Main Menu screen reappears.

- To go directly past the Main Menu screen to the normal screen, press MENU.

8 CLOSE MAIN MENU

Press MENU. The normal screen reappears.

**MAIN MENU**

Tele Macro	OFF	Usually set to this position.
	◆ ON	Usually the distance to a subject where the lens is in focus depends on the zoom magnification. Unless there is a distance more than 1m to the subject, the lens is out of focus at the maximum telephoto setting. When set to "ON", you can shoot a subject as large as possible at a distance of approx. 60 cm. • Depending on the zoom position, the lens may go out of focus.
Gain UP	AGC	Allows you to record a subject in a dark environment. It delivers a brighter, if slightly coarse, picture.
	◆ OFF	Allows you to shoot dark scenes with no picture brightness adjustment.
Color Filter	NOR.	For normal shooting with no colour adjustment.
	◆ RED	Gives recording a reddish tint.
	◆ BLUE	Gives recording a bluish tint.
Tape Length	Allows you to set the tape length depending on the tape used (☞ pg. 8).	
Title	Allows you to superimpose a preset title onto a scene (☞ pg. 28).	
Date/Time	Allows you to set the current date and time (☞ pg. 7).	

 = Factory setting

SUB MENU

Tally	ON	The tally lamp comes on to signal the start of recording.
	OFF	The tally lamp remains off at all times.
Interval Timer and Rec. Time	These features allow you to set the parameters for Self-Timer (☞ pg. 30), Animation and Time-Lapse recording (☞ pg. 31).	
JLIP ID NO.	This number will be necessary in the future when connecting the camcorder to a device such as a computer using the JLIP terminal. The numbers range from 01 — 99.	

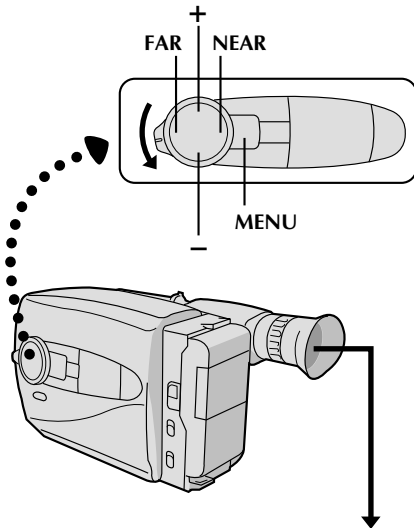

Tele Macro	OFF
Gain Up	AGC
Color Filter	NOR.
Tape Length	T45
Title	
Date/Time	
Sub Menu	

OFF
Happy Birthday
Happy Holidays
Our Family
Movie Star
Party Time
Merry Christmas
Wedding Day
Congratulations
(Set Character)

Congratulations

Instant Titles

You can superimpose one of 7 preset titles, or a title you made yourself, onto a scene.

- 1 SELECT SHOOTING MODE**
Set the Shooting Mode selector to "PRESET".

- 2 ACCESS MAIN MENU SCREEN**
Press **MENU**.

- 3 ACCESS INSTANT TITLE MENU SCREEN**
Press **+** or **-** to move the highlight bar to "Title", then press **NEAR**. The Title menu appears.

- 4 SELECT PRESET TITLE**
Press **+** or **-** to move the highlight bar to the desired title. (To create an original title, refer to page 29.)

- 5 DISPLAY PRESET TITLE**
Press **MENU**. The Title menu disappears, and the selected title is displayed on the screen.



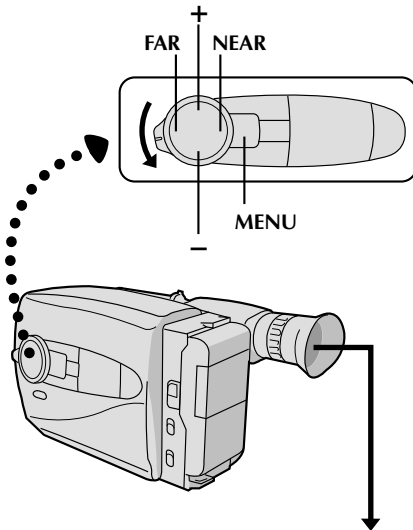

Character Generator

You can enter an original title of up to 18 characters. Perform steps 1, 2 and 3 of the "Instant Title" procedure (pg. 28) before continuing.

1 ACCESS CHARACTER SET MENU

Press + or - to move the highlight bar to "(Set Character)", then press NEAR. The Character Set menu appears.

2 INPUT CHARACTERS

Press +, -, FAR or NEAR to move the blinking cursor to the desired character, then press MENU. The selected characters appear at the bottom of the screen. Repeat as many times as desired (max. 18).

- To select the location of the next character, press +, -, FAR or NEAR to move the blinking cursor to the row of squares at the bottom of the screen, then press FAR or NEAR to move the blinking cursor underneath the desired location. Press + when you're done, and the blinking cursor returns to the character grid.

3 END CHARACTER SETTING

Press +, -, FAR or NEAR to move the cursor to "End", then press MENU. The Character Set menu disappears and the Preset Title menu reappears. Press MENU to return to the normal screen.

NOTE:

To erase a character you entered mistakenly, place the cursor by "Clear" by pressing +, -, FAR or NEAR, then press MENU. All characters are deleted at once. Or, to erase selected characters only, place the blinking cursor at the character at the bottom you want to replace, then press +/- . "□" in the top left corner is highlighted.



30_{EN}

RECORDING Advanced Features (cont.)

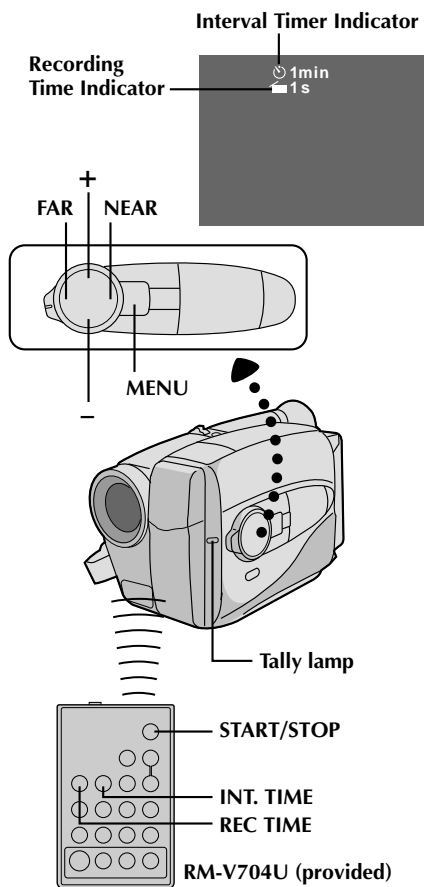

Tele Macro	OFF
Gain Up	AGC
Color Filter	NOR.
Tape Length	T45
Title	
Date/Time	
Sub Menu	

Main Menu Screen

Tally	ON
Interval Timer	OFF
Rec Time	OFF
JLIP ID NO.	07

Sub Menu Screen

Self-Timer

You can set the delay between pressing the Recording Start/Stop button and the actual start of recording. If you secure the camcorder, you (or whomever is operating the camcorder) can enter the scene before recording starts.

1 ENGAGE RECORD-STANDBY MODE

Make sure the lens cover is open, then set the Power switch to "CAMERA".

2 SELECT MODE

Set the Shooting Mode selector to "PRESET".

3 ACCESS MAIN MENU SCREEN

Press MENU.

4 ACCESS SUB MENU SCREEN

Press - to move the highlight bar down to "Sub Menu", then press NEAR. The Sub Menu screen appears.

5 SET INTERVAL TIME

Press - to move the highlight bar down to "Interval Timer", press NEAR, then press + or - to cycle through the choices. Stop when the desired time appears. Choose from "15S", "30S", "1min", "5min", or select to turn the function "OFF". Then press FAR twice to return to the Main Menu screen.

6 CLOSE MAIN MENU

Press MENU.

7 START DELAYED RECORDING

Press the Recording Start/Stop button. If you set the tally lamp to "ON" (pg. 27), it begins blinking, and the blinking frequency increases about 5 seconds before recording is to start. Once recording begins, the lamp stops blinking but stays lit.

To Release Self-Timer . . .

... while the tally lamp is blinking, press the Recording Start/Stop button to stop the blinking, then set "Interval Timer" to "OFF" or press INT. TIME on the remote control until "☺" disappears.

... while the tally lamp is lit but not blinking, press set "Interval Timer" to "OFF" or press INT. TIME on the remote control until "☺" disappears.

NOTE:

Instead of performing steps 2 - 6, you can set the interval time by pressing INT. TIME on the remote control.



Animation

Give stationary scenes or objects an illusion of movement. This function allows you to shoot a series of pictures, each slightly different, of the same object for a brief period of time.

ENGAGE RECORD-STANDBY MODE

1 Make sure the lens cover is open, then set the power switch to "CAMERA".

SET RECORDING SPEED

2 Set SP/LP to SP (☞ pg. 9).

SET RECORDING TIME

3 Press **REC TIME** on the remote control. Four choices are available, and they appear in the following order (each time **REC TIME** is pressed): 1/4S (one-fourth of a second), 1/2S (one-half of a second), 1S (one full second) and 5S (five seconds). Press again to release the Animation mode.

- You can also set the recording time in the Sub Menu screen (☞ pg. 30). Press "-" to move the highlight bar down to "Rec Time", press **NEAR**, and press + or - to cycle through the choices. Then press **MENU**.

START RECORDING

4 Press the Recording Start/Stop button after focusing on the subject. The recording stops automatically after the selected period of time.

ASSEMBLE SERIES OF PICTURES

5 Repeat steps 3 and 4 for the desired number of pictures.

CHECK YOUR WORK

6 Play back the series of pictures to see if the results were satisfactory.

RELEASE ANIMATION MODE

7 Press **REC TIME** until "■" disappears from the viewfinder, or set "Rec Time" in the Sub Menu screen to "OFF".

NOTES:

- For best results, make sure the camcorder is secured when shooting in Animation or Time-Lapse mode.
- Fade-in/out cannot be performed during Animation or Time-Lapse shooting.
- Before performing other operations following Animation or Time-Lapse recording, make sure the Animation or Time-Lapse mode is deactivated.

Time-Lapse

You can record sequentially at preset time spans. Leaving the camcorder aimed at a specific subject, you can record subtle changes over an extended period of time.

ENGAGE RECORD-STANDBY MODE

1 Make sure the lens cover is open, then set the power switch to "CAMERA".

SET RECORDING SPEED

2 Set SP/LP to SP (☞ pg. 9).

SET RECORDING TIME

3 Press **REC TIME** on the remote control. There are four choices available, and they appear in the following order (each time **REC TIME** is pressed): 1/4S, 1/2S, 1S, and 5S. Press again to reset.

- You can also set the recording time in the Sub Menu screen. Press "-" to move the highlight bar down to "Rec Time", and press **NEAR**, then press + or - to cycle through the choices.

SET INTERVAL BETWEEN RECORDINGS

4 Press **INT. TIME** on the remote control. There are five choices available, and they appear in the following order (each time **INT. TIME** is pressed): OFF, 15S, 30S, 1 min, and 5 min. Press again to reset.

- You can also set the interval time in the Sub Menu screen. Press "-" to move the highlight bar down to "Interval Timer", press **NEAR**, and press + or - to cycle through the choices.
- Exposure control (☞ pg. 18), manual focusing (☞ pg. 21) and D.I.S. settings (☞ pg. 18) should be performed at this point. Once you perform step 5, these settings cannot be changed.

START TIME-LAPSE RECORDING

5 Press the Recording Start/Stop button. Recording and intervals alternate automatically.

RELEASE TIME-LAPSE MODE

6 To release when the tally lamp is not blinking, press **INT. TIME** and **REC TIME** repeatedly until "■" and "⊙" disappear. To release when the tally lamp is blinking, press the Recording Start/Stop button to stop the blinking, then press **INT. TIME** and **REC TIME** repeatedly until "■" and "⊙" disappear, or set "Interval Timer" and "Rec Time" in the Sub Menu screen to "OFF".

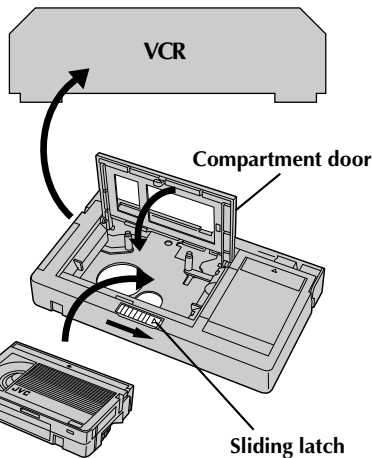
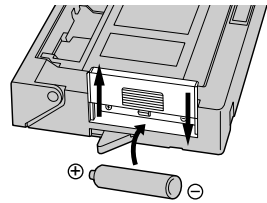

Compact video cassette

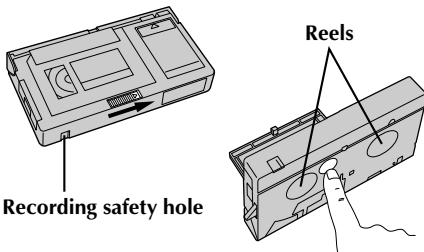
**Cassette Adapter**

Use this to play back a VHS-C video cassette recorded with this camcorder. It is fully compatible with any VHS video cassette recorder. The C-P7U adapter is battery powered and automatically performs tape loading and unloading.

1 INSERT BATTERY

Slide the battery cover up to remove it, and install one "R6(AA)" size battery as shown in the illustration at left. Then reattach the cover.

2 INSERT CASSETTE IN ADAPTER

Slide the latch to open the adapter compartment door, then insert the cassette and close the compartment door.

3 PLAY BACK ON CONNECTED VCR

Load the cassette adapter into the VCR and play the tape back as you would any other.

4 REMOVE CASSETTE FROM ADAPTER

Slide the latch and the compartment door opens automatically. Then insert your finger in the hole on the underside of the adapter as shown in the illustration at left, push up and remove the cassette.

NOTES:

- During tape loading and unloading, do not touch the reels for safety and tape protection.
- During special-effect playback (slow motion, still frame, etc.), the picture may vibrate or noise bars may appear on the screen.
- To record on a VCR using a compact cassette and the adapter, cover the adapter's recording safety hole with adhesive tape.

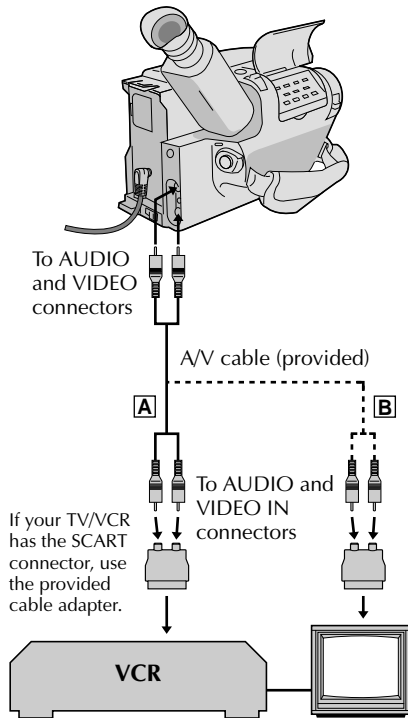

There are two basic types of connections. When making the connections, refer also to your VCR and TV instruction manuals.

Connection To A VCR [A] (Editing, Dubbing and Playback)

NOTE:

Use the provided A/V cable.

1 CONNECT CAMCORDER TO VCR

As shown in the illustration at left, connect the provided A/V cable. between the AUDIO and VIDEO connectors on the camcorder and those on the VCR.

2 SUPPLY POWER

Turn on the camcorder, the VCR and the TV.

3 SELECT MODE

Set the VCR to its AUX input mode, and set the TV to its VIDEO mode.

Connection To A TV With A/V Input Connectors [B] (Playback ONLY)

NOTE:

Use the provided A/V cable.

1 CONNECT CAMCORDER TO TV

As shown in the illustration at left, connect the provided A/V cable. between the AUDIO and VIDEO connectors on the camcorder and those on the TV.

2 SELECT MODE

Set the TV to its VIDEO or AV mode (as specified in its instructions).

NOTES:

- It is recommended to use the AC Power Adapter/Charger as the power supply instead of the battery pack.
- To monitor the picture and sound from the camcorder without inserting a tape, set the camcorder's power switch to CAMERA, then set your TV to the appropriate input mode.
- If you have a TV or speakers that are not specially shielded, do not place the speakers adjacent to the TV as interference will occur in the camcorder playback picture.

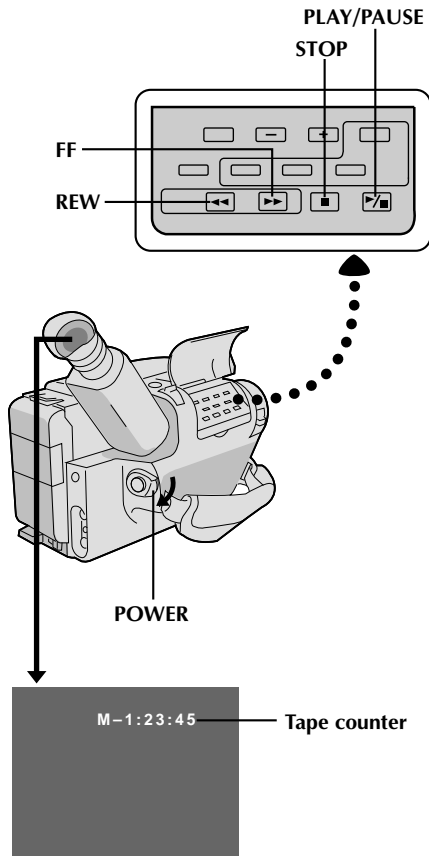

NOTE:

Make sure you connect your camcorder as directed in "Basic Connections" (pg. 33).

- 1 LOAD A CASSETTE**
Load as you did in the recording procedure.
- 2 SELECT MODE**
Set the Power switch to "PLAY". The Power On indicator lights.
- 3 PLAYBACK**
Press **PLAY/PAUSE**. The playback picture appears in the viewfinder and the connected TV.
- 4 STOP PLAYBACK**
Press **STOP**.

Rewind or Fast-forward the tape

Press **REW** to rewind, or **FF** to fast-forward the tape during Stop mode.

NOTE:

The camcorder shuts off automatically after about 5 minutes in *STOP* mode. To turn on again, set the Power switch to "POWER OFF", then to "PLAY".





PLAYBACK Features

EN 35

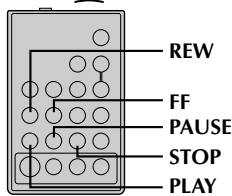
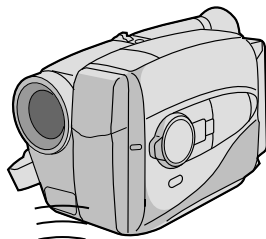
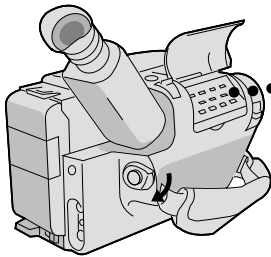
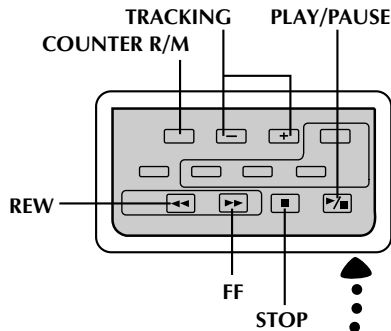

RM-V704U (provided)

FEATURE:	Manual Tracking
PURPOSE:	To eliminate noise bars that appear on the screen.
OPERATION:	1) Press either TRACKING button as many times as necessary for best picture.
NOTES:	<ul style="list-style-type: none"> • To reset TRACKING to the original preset, press both TRACKING buttons simultaneously. • Manual Tracking may not work with tapes recorded on other VCRs or camcorders.
FEATURE:	Still Playback
PURPOSE:	To pause during playback.
OPERATION:	1) Press PLAY/PAUSE during playback. 2) To resume normal playback, press PLAY/PAUSE again.
NOTE:	Noise bars appear and pictures may become monochrome during Still Playback. This is normal.
FEATURE:	Shuttle Search
PURPOSE:	To allow high-speed search in either direction.
OPERATION:	Forward Search 1) Press FF during playback. Reverse Search 1) Press REW during playback.
NOTE:	Noise bars appear and pictures may become monochrome or darken in Shuttle Search. This is normal.
FEATURE:	Counter Memory Function
PURPOSE:	To make it easier to locate a specific tape segment.
OPERATION:	1) Press COUNTER R/M and hold for more than 2 seconds. The counter resets to "0:00:00". 2) Press COUNTER R/M . "M" appears. 3) After recording or playback, press STOP , then REW . The tape automatically stops at or close to 0:00:00. 4) Press PLAY/PAUSE to start playback.
NOTES:	<ul style="list-style-type: none"> • The counter memory functions in the FF and REW modes. • To disable Counter Memory Function, press COUNTER R/M so the "M" disappears.

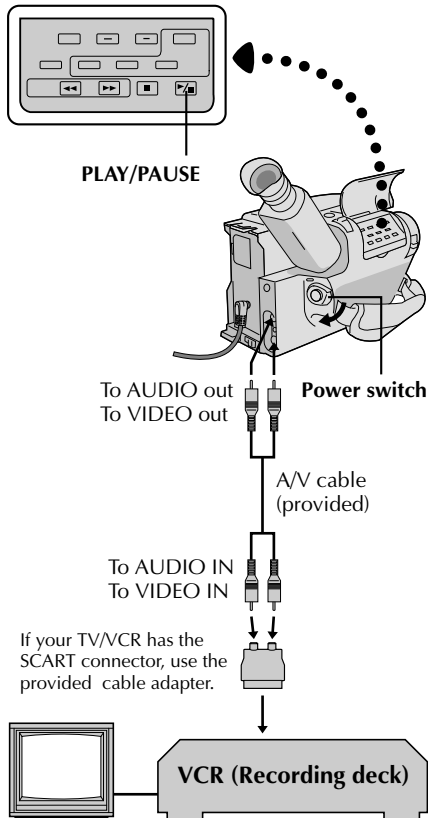

Tape Dubbing

1 CONNECT EQUIPMENT

Following the illustration at left, connect the camcorder and the VCR.

2 PREPARE FOR DUBBING

Set the camcorder's power switch to PLAY, turn on the VCR's power, and insert the appropriate cassettes in the camcorder and the VCR.

3 SELECT VCR MODE

Engage the VCR's AUX and Record-Pause modes.

4 FIND EDIT-IN POINT

Engage the camcorder's Play mode to find a spot just before the edit-in point. Once it's reached, press **PAUSE** on the camcorder.

5 START EDITING

Press **PLAY** on the camcorder and engage the VCR's Record mode.

6 STOP EDITING TEMPORARILY

Engage the VCR's Record-Pause mode and press **PAUSE** on the camcorder.

7 EDIT MORE SEGMENTS

Repeat steps 4 through 6 for additional editing, then stop the VCR and camcorder when finished.

Random Assemble Editing [R.A.Edit]

Create edited videos easily using your camcorder as the source player. You can select up to 8 "cuts" for automatic editing, in any order you like. R.A. Edit is more easily performed when the RM-V704U MBR (Multi-Brand Remote) is set to operate with your brand of VCR (see chart on the next page), but can also be performed by operating the VCR manually.

CONTINUED ON NEXT PAGE

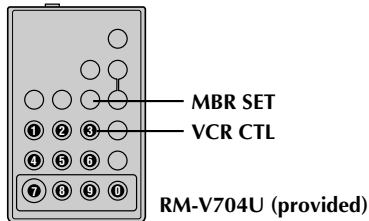

VCR CODE LIST

VCR BRAND NAME	BUTTONS (A) (B)	VCR BRAND NAME	BUTTONS (A) (B)
AKAI	6 2 6 4 7 7	PHILIPS	1 9 9 5 1 1 9 4 9 1 9 6 1 2 3 3
BLAUPUNKT	1 9	SANYO	3 6 3 5
FERGUSON	9 7 9 8 9 2	SELECO, REX	9 1 9 6
GRUNDIG	1 4 3 4	SHARP	1 5 1 0
HITACHI	6 6 6 3	SONY	6 5 6 0 3 9 3 1
JVC A B C	9 1 9 6 9 3	THOMSON, TELEFUNKEN, SABA, NORDMENDE	9 1 9 6 9 7 3 2
MITSUBISHI	6 7 6 8	TOSHIBA	6 9 6 1
NEC	3 7 3 6		
PANASONIC	1 9 1 7 1 1 9 4 1 8		

SET REMOTE/VCR CODE

SET REMOTE TO OPERATE VCR

1 Turn off the power to the VCR and point the remote toward the VCR's infrared sensor. Then, referring to the chart at left, press and hold **MBR SET**, and press button (A) and then (B).

- The code is automatically set once you release the **MBR SET** button, and the VCR's power comes on.

OPERATE THE VCR

2 Make sure the VCR's power is on. Then, while holding **VCR CTL**, press the button on the remote for the desired function. The functions the remote can control are PLAY, STOP, PAUSE, FF, REW and VCR REC STBY (you don't need to press **VCR CTL** for this one).

You're now ready to try Random Assemble Editing.

IMPORTANT

Although the MBR is compatible with JVC VCRs and those of many other makers, it may not work with yours or may offer limited functions.

NOTES:

- If the VCR's power doesn't come on in step 1, try another code from the chart.
- Some brands of VCR don't come on automatically. In this case, turn the power on manually and try step 2.
- If the RM-V704U is not able to control the VCR, use the controls on the VCR.

MAKE CONNECTIONS

CONNECT TO . . .

1 **A** JVC VCR EQUIPPED WITH REMOTE PAUSE TERMINAL

Connect the editing cable to the Remote PAUSE terminal.

B JVC VCR NOT EQUIPPED WITH REMOTE PAUSE TERMINAL

Connect the editing cable to the R.A. EDIT connector.

C NON-JVC VCR WITH NEITHER

Connect the editing cable to the RM-V704U's Pause-In jack.

All other connections are as shown in the illustration on page 38

CONTINUED ON NEXT PAGE

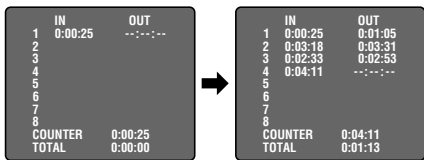
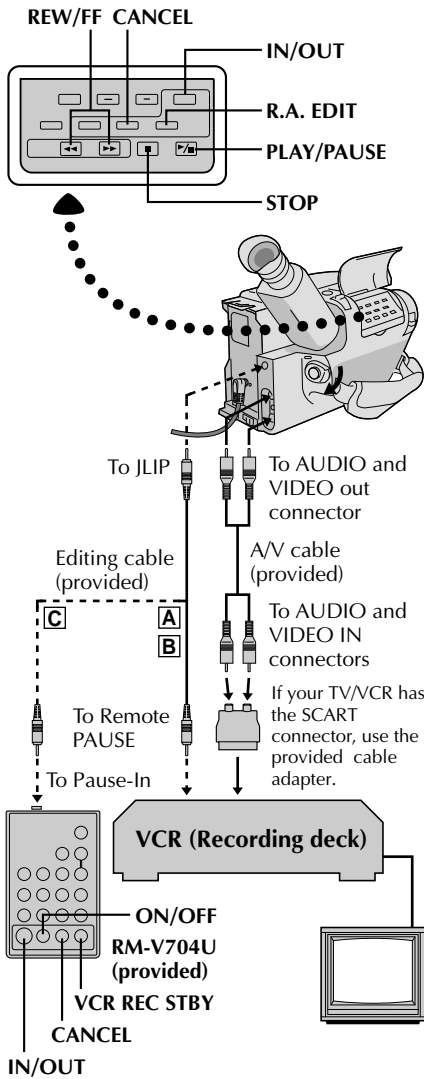

PREPARE CAMCORDER

2 Insert a recorded tape and set the power switch to PLAY.

PREPARE VCR

3 Turn the power on, insert a recordable tape and engage the AUX mode (refer to VCR's instructions).

SELECT SCENES

ACCESS R.A. EDIT COUNTER DISPLAY

1 Press **PLAY/PAUSE**, then press **R.A. EDIT** and the counter display appears in the viewfinder and the screen of the connected TV.

REGISTER BEGINNING OF SCENE

2 Press **REW** or **FF** to locate the beginning of a scene you want, then press **IN/OUT** to register that point. The data appears under IN on the display.

REGISTER END OF SCENE

3 Press **REW** or **FF** to locate the end of the scene and press **IN/OUT** to register it. The data appears under OUT on the display. The total time of the registered scene(s) is displayed at the bottom of the screen.

REGISTER ADDITIONAL SCENES

4 Repeat steps 2 and 3 for each additional scene (as many as 8).

MAKE CORRECTIONS

5 Press **CANCEL** during steps 2 and 3 to erase the most recently registered point.

NOTES:

- The RM-V704U can be used to operate other camcorder functions as well. Point the RM-V704U at the camcorder's remote sensor and press any of the following buttons (function appears in parentheses):
 - ON/OFF (camcorder R.A. EDIT)
 - IN/OUT (camcorder IN/OUT)
 - CANCEL (camcorder CANCEL)
- There must be at least one second between an in-point and its corresponding out-point.
- To ensure correct operation, leave at least 15 seconds open between scenes.
- Blank portions of tape cannot be registered as in-points or out-points.
- If it takes more than 5 minutes to search for an in-point, the VCR's Record-Pause mode is cancelled and editing doesn't take place.
- Pressing **R.A. EDIT** clears all in- and out-points from memory.
- Leave a small margin for error around each in-point to ensure the scene is recorded in its entirety.



ORIGINAL TAPE (camcorder)

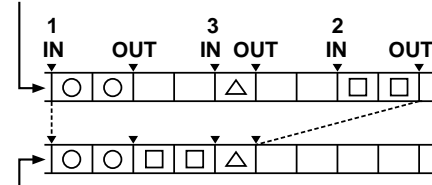

EDITED TAPE (VCR)

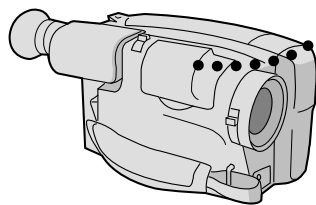
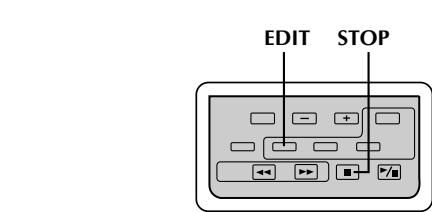

AUTOMATIC EDITING TO VCR

ENGAGE VCR'S RECORD-PAUSE MODE

- 1 Point the remote control toward the VCR's infrared sensor and press **VCR REC STBY**, or manually engage the VCR's Record-Pause mode.

BEGIN AUTOMATIC EDITING

- 2 Press **EDIT** on the camcorder, and the previously selected scenes are copied to the VCR in the specified order.

END AUTOMATIC EDITING

- 3 When all selected scenes have been copied, the camcorder and VCR enter the still or pause mode. Press **STOP** on both units.

- When finished editing, be sure to disconnect the editing cable and the audio/video cable.

NOTES:

- If you performed step 1  on page 37 ("MAKE CONNECTIONS"), keep the remote control pointed at the VCR during editing.
- The on-screen display only appears while the camcorder searches for each scene.
- There may be noise at in- or out-points on the edited tape with certain VCRs.

SUPPLEMENTAL INFORMATION ON THE REMOTE CONTROL

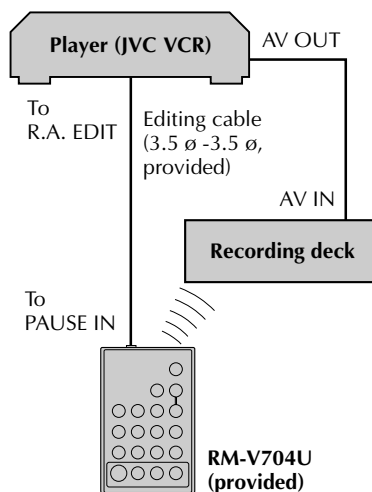

Using the RM-V704U remote control, it is also possible to perform deck-to-deck Random Assemble Editing. The playback deck must be an R.A. Edit-capable JVC VCR. The recording deck can be...

- a VCR other than JVC, or
- a JVC VCR which has **neither** a Remote PAUSE nor an R.A. EDIT connector

How to use:

- Connect the playback deck and RM-V704U as shown on the left.
- Set the RM-V704U to correspond to the brand of the recording deck. (☞ pg. 37)
- For Random Assemble Editing procedure, please refer to the instruction manual of the JVC VCR you are using as the playback deck.

Notes:

- RM-V704U cannot be used to control the playback deck.
- RM-V704U is capable of controlling basic operations of the recording deck. While pressing VCR CTL, press PLAY, STOP, PAUSE, FF or REW for these functions. (Not possible with some brands and models). Other buttons cannot be used.
- To put the recording deck in the Record-Pause mode, use the controls on the recording deck itself.

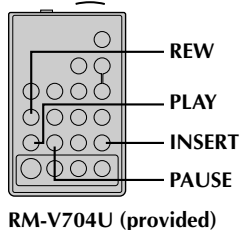
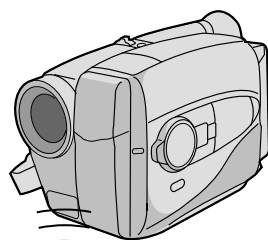
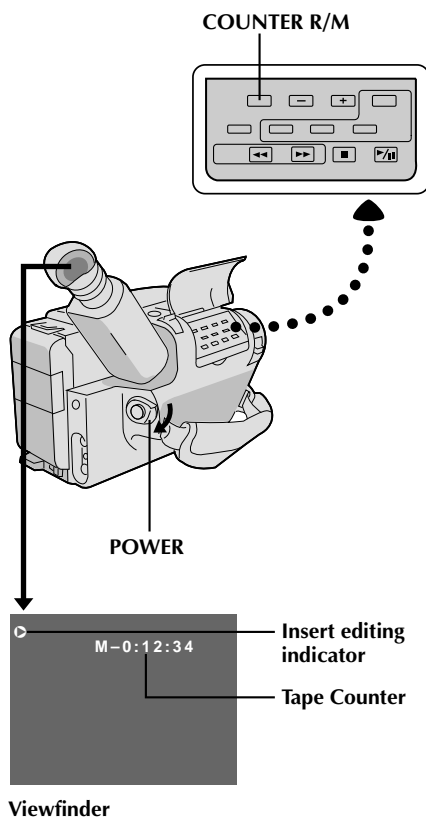

Insert Editing

You can record a new scene into a previously recorded tape, replacing a section of the original recording with minimal picture distortion at the in- and out-points. The original audio remains unchanged.

NOTE:

Use the RM-V704U remote control unit to perform this procedure.

1 SELECT MODE

Set the Power switch to "PLAY".

2 FIND EDIT-OUT POINT

Locate the point and press **PAUSE** on the camcorder or the remote control.

3 RESET COUNTER

Press and hold **COUNTER R/M** for more than 2 seconds to reset the tape counter, then press for less than 1 second and make sure "M" appears in the viewfinder.

4 FIND EDIT-IN POINT

Press **REW** to go a little beyond the beginning of the scene you want to replace, press **PLAY** to view the recorded tape, and press **PAUSE** at exactly at the point where the new scene should start.

5 ENGAGE INSERT EDITING MODE

Press and hold **INSERT**, and without releasing **INSERT**, press and release **PAUSE**. The Insert mode is engaged, and the scene the camcorder is aimed at appears on the screen.

6 BEGIN INSERT EDITING

Press the Recording Start/Stop button. When the counter reaches "0:00:00", editing stops automatically and the camcorder enters the Insert-Pause mode.

7 END INSERT EDITING

Press **STOP**.

• If a Fade/Wipe effect was in use during Insert Editing, wait about 10 seconds after pressing **STOP** before performing other operations.

NOTES:

- After step 5, Retake (pg. 14) can be performed.
- The tape may stop slightly before or after the designated end point, and noise bars may appear. Neither indicates a defect in the unit.
- Only video signal is recorded in the Insert Editing mode.

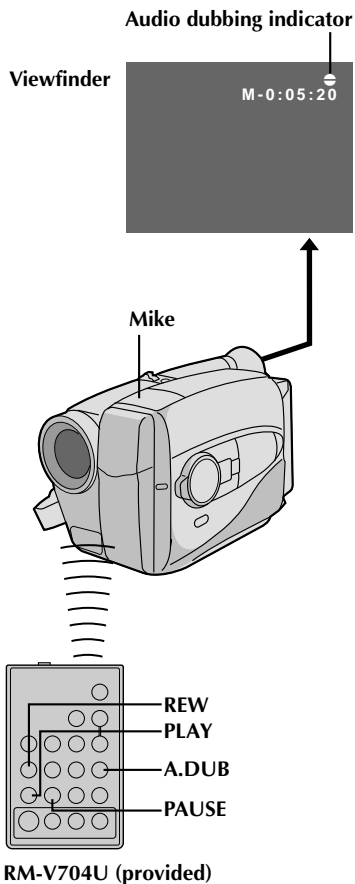

Audio Dubbing

You can record a new soundtrack on a prerecorded tape (normal audio only).

** Perform steps 1, 2 and 3 of the Insert Editing procedure (pg. 40) before continuing.

- The sound comes from the built-in mike.

1 FIND EDIT-IN POINT

- Press **REW** to go a little beyond the beginning of the scene onto which you want to dub new audio, press **PLAY** to view the recorded tape, then press **PAUSE** at exactly the point where dubbing should start.

2 ENGAGE AUDIO DUB STANDBY MODE

- Press and hold **A. DUB**, and without releasing **A. DUB**, press and release **PAUSE**.

3 BEGIN AUDIO DUBBING

- Press **PLAY/PAUSE**. When the counter reaches "0:00:00", Audio Dubbing stops automatically and the camcorder enters the Audio Dub-Standby mode.

4 END AUDIO DUBBING

- Press **STOP**.

NOTES:

- Do not press **FF** or **REW** during Audio Dub-Standby, or the edit points will not be accurate.
- If the mike is too close to the TV, or if the TV's volume is too high, whistling or howling may occur.
- If the camcorder is connected to the TV, noise may appear on the screen and pictures may become monochrome during the Audio Dubbing procedure. This phenomenon is not recorded on the tape.

NOTES (for Insert Editing and Audio Dubbing):

- Insert Editing and audio Dubbing may not work correctly if the tape contains blank segments, or if the recording speed was changed during the original recording.
- To edit/dub onto a tape with the recording safety tab removed, cover the hole with adhesive tape.
- Do not press **STOP** during Insert Editing or Audio Dubbing, or the edit points will not be accurate.
- During Insert Editing and Audio Dubbing, when Insert-Pause or Audio Dub-Standby is engaged, the counter may go slightly past "0:00:00". Recording, however, stops at exactly 0:00:00.

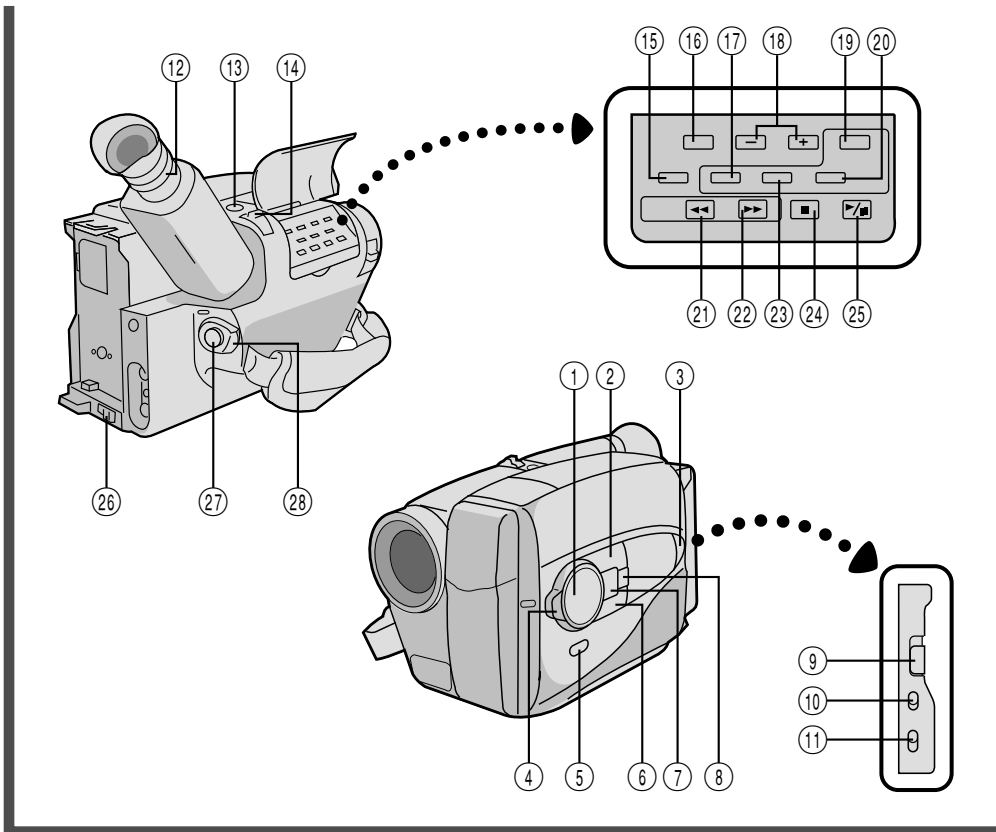

Controls

- ① Multi-Function Control [FAR/NEAR/+/- Buttons] pg. 7
- ② EFFECT/PROG.AE Button pg. 22
- ③ PUSH Button pg. 9
- ④ Shooting Mode Selector pg. 7
- ⑤ DISPLAY Button pg. 16
- ⑥ FADE/WIPE Button pg. 24
- ⑦ MENU Button pg. 7
- ⑧ D.I.S. [Digital Image Stabilizer] Button pg. 18
- ⑨ EJECT Switch pg. 9
- ⑩ AUTO PAUSE ON/OFF Switch pg. 14
- ⑪ LIGHT ON/AUTO/OFF select switch pg. 15
- ⑫ Diopter Adjustment pg. 6
- ⑬ QUICK REC Button pg. 17
- ⑭ Power Zoom Lever pg. 13
- ⑮ MWB [Manual White Balance] Button pg. 19
- ⑯ Recording Mode [SP/LP] Select Button pg. 9
- COUNTER R [Reset]/M [Memory] Button pg. 35
- ⑰ EDIT Button pg. 39
- ⑱ TRACKING +/- Buttons pg. 35
- ⑲ R.A.EDIT IN/OUT Button pg. 38
- ⑳ R.A.EDIT Button pg. 38
- ㉑ REW Button pg. 34
- RETAKE R [Quick Review] Button pg. 13
- ㉒ FF Button pg. 34
- RETAKE F Button pg. 14
- ㉓ R.A.EDIT CANCEL Button pg. 38
- ㉔ STOP Button pg. 34
- ㉕ PLAY/PAUSE Button pg. 34
- ㉖ BATT. [Battery] RELEASE Switch pg. 4
- ㉗ Recording Start/Stop Button pg. 12
- ㉘ POWER Switch pg. 6

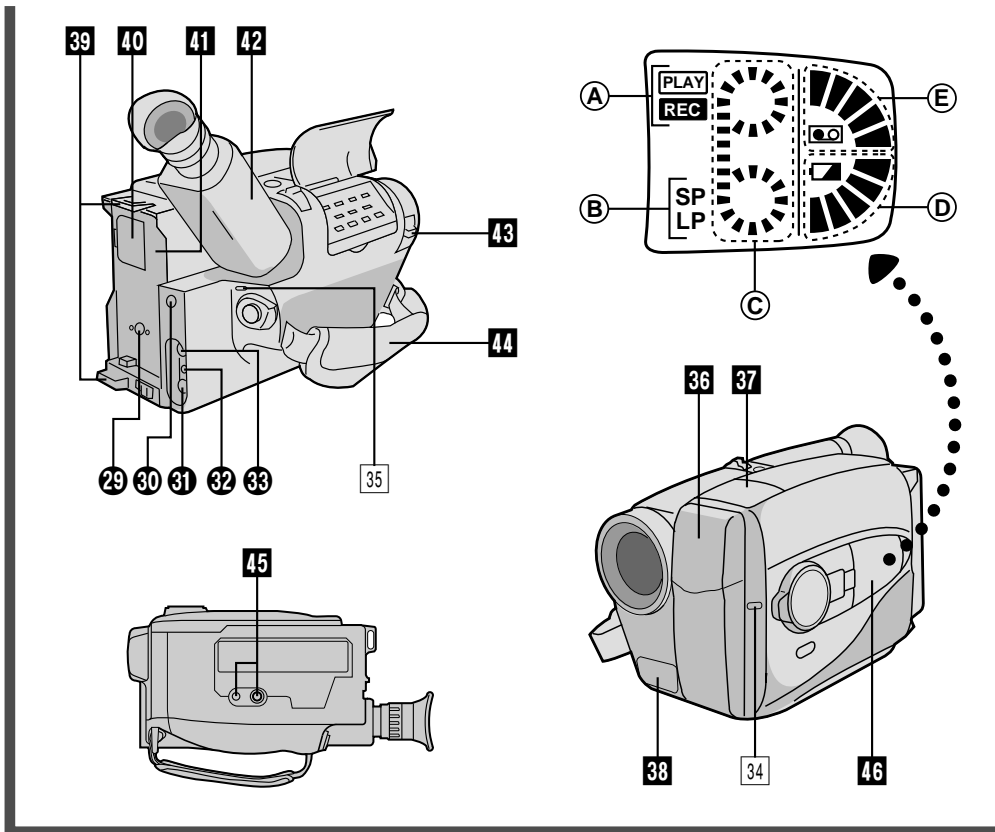

Connectors

- 29 DC IN Jack pg. 5
- 30 JLIP (Joint Level Interface Protocol) Connector.
 - Connect the Editing Cable when performing Random Assemble Editing (pg. 38).
 - In the future, it will be used to connect the camcorder to a device such as a personal computer.
- 31 VIDEO Out Jack pg. 33
- 32 RF DC OUT Jack
- 33 AUDIO Out Jack pg. 33

Indicators

- 34 Tally Lamp pg. 12
- 35 Power On Indicator pg. 12

Other Parts

- 36 Video Light pg. 15
- 37 Microphone pg. 41
- 38 Infrared beam sensor window pg. 11
(Be careful not to cover this area; built-in here is the sensor necessary for shooting.)
- 39 Shoulder Strap Eyelets pg. 10
- 40 Clock Battery Compartment pg. 6
- 41 Battery Pack Mount pg. 4
- 42 Electronic Viewfinder pg. 6
- 43 LENS COVER Switch pg. 12
- 44 Grip Strap pg. 10
- 45 Tripod Mounting Socket pg. 10
- 46 LCD window
 - A Operating Mode (Playback//Recording) Indicator
 - B Recording Mode Indicator
 - C Tape Running Indicator
 - D Remaining Battery Power Indicator
 - E Tape Loaded/Remaining Tape Indicators

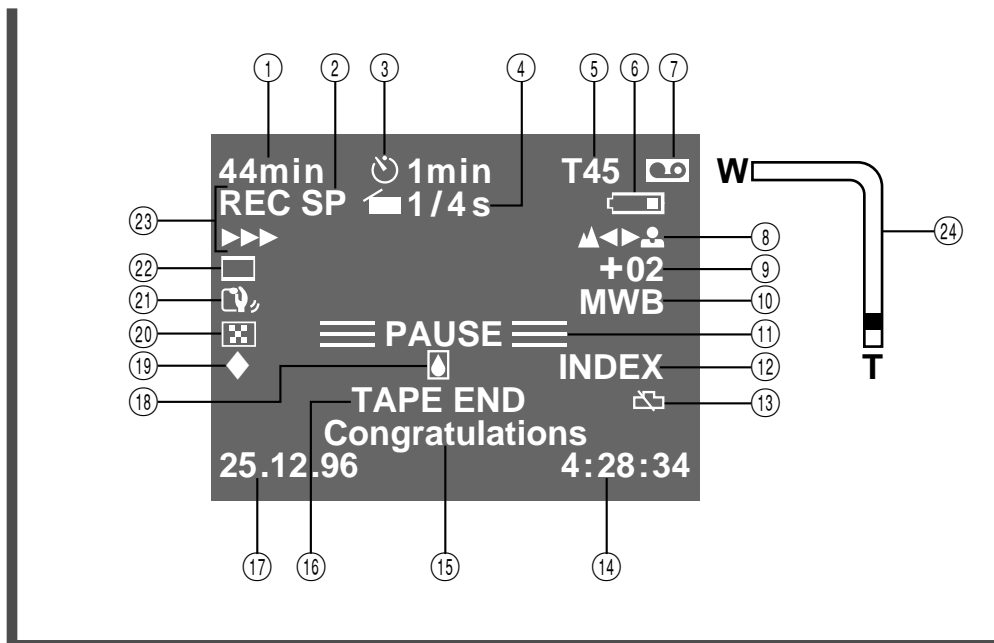

Viewfinder Indications

- ① Remaining Tape Time pg. 12
- ② Recording Mode [SP/LP] Indicator pg. 9
- ③ Interval Timer Indicator pg. 30
- ④ Recording Time Indicator pg. 31
- ⑤ Tape Length Display pg. 8
- ⑥ Battery Pack Remaining Power Indicator pg. 4
Changes as follows according to the battery pack's remaining power level:
"■■■■-■■■-■■-■-□". When the power is almost gone, the indicator blinks, then the unit shuts off. Replace the battery pack with a fully charged one.
(Note: The symbol containing 3 darkened squares — ■■■ — does not necessarily mean that the battery pack is fully charged.)
- ⑦ Cassette Indicator
Blinks when no cassette inserted; remains steadily lit when cassette inserted.
- ⑧ Focus Indicator pg. 20
- ⑨ Exposure Level Display pg. 18
- ⑩ White Balance Mode Indicator pg. 19
- ⑪ Record-Standby Mode Indicator pg. 12
- ⑫ Index Code Marking pg. 14
- ⑬ Clock Warning
Once the power is turned on and the indicator blinks for about 10 seconds, perform the date and time settings (pg. 7). After setting is complete, turn the power off and disconnect the power source. If you re-connect it and turn the power on and the indicator is blinking, that means that the clock (lithium) battery is either not installed or has discharged. Install, or replace the old battery with, a new one (pg. 6).
- ⑭ Time Display pg. 16
- ⑮ Instant Title Display pg. 28
- ⑯ Tape End Display pg. 12
Appears when the end of the tape is reached during playback, recording or fast-forward.
- ⑰ Date Display pg. 16
- ⑱ Condensation Warning
When this indication appears, all functions are disabled. Turn the unit off (without removing the power source) for a few hours, and when you turn it on again the indicator should disappear.
- ⑲ Main Menu Setting Change Indicator pg. 27
- ⑳ Fade/Wipe indicator pg. 25
- ㉑ D.I.S. (Digital Image Stabilizer) Indicator pg. 18
- ㉒ EFFECT/PROG.AE indicator pg. 23
- ㉓ Recording Indicator pg. 12
- ㉔ Zoom Indicator Bar pg. 13



CAUTIONS

EN 45

DANGER:

- The video light becomes extremely hot. Do not touch it either while in operation or soon after turning it off, otherwise serious injury may result.
- Do not place the camcorder into the carrying case immediately after using the video light, since it remains extremely hot.
- When operating, keep a distance of about 30 cm between the video light and people or object.
- Do not use near flammable or explosive materials.
- Consult your nearest JVC dealer for replacing the video light unit.

General Battery Precautions

- When the C-P6U or C-P7U (cassette adapter) is not functioning even when correctly operated, the batteries are exhausted. Replace them with fresh ones.
- Use only the following batteries:

C-P6U or C-P7U R6 (AA) size

Please make note of the following rules for battery use. When misused, batteries can leak or explode.

1. Refer to the instructions when replacing batteries.
2. **Do not** use old and new batteries together.
3. **Do not** use two different kinds of batteries. Although sizes may be the same, voltages may differ.
4. **Do not** expose batteries to excessive heat as they can leak or explode.
5. **Do not** dispose of batteries in a fire.
6. Remove batteries from the unit if it is to be stored for an extended period to avoid battery leakage which can cause malfunctions.

Battery Packs

The supplied battery pack is a nickel-cadmium battery. Before using the supplied battery pack or an optional battery pack, be sure to read the following cautions:

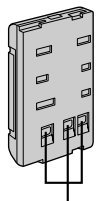

Terminals

1. To avoid hazard . . .

- **do not** burn.
- **do not** short-circuit the terminals.
- **do not** modify or disassemble.
- use only specified chargers.

2. To prevent damage and prolong service life . . .

- **do not** subject to unnecessary shock.
- avoid repeated charging without fully discharging.

- charge in an environment where temperatures are within the tolerances shown in the chart below. This is a chemical reaction type battery—cooler temperatures impede chemical reaction, while warmer temperatures can prevent complete charging.
- store in a cool, dry place. Extended exposure to high temperatures will increase natural discharge and shorten service life.
- avoid prolonged uncharged storage.
- remove from charger or powered unit when not in use, as some machines use current even when switched off.

3. To prevent damage to the camcorder . . .

- replace the battery pack when it begins to deliver less recording time per charge.

NOTE:

It is normal for the battery pack to be warm after charging, or after use.

Temperature Ranges

Charging 10°C to 35°C

Operation 0°C to 40°C

Storage -10°C to 30°C

NOTES:

- *Recharging time is based on room temperature of 20°C.*
- *The lower the temperature, the longer recharging takes.*

Cassettes

To properly use and store your cassettes, be sure to read the following cautions:

1. During use . . .

- make sure the cassette bears the VHS-C mark.
- be aware that recording onto prerecorded tapes automatically erases the previously recorded video and audio signals.
- make sure the cassette is positioned properly when inserting.
- do not load and unload the cassette repeatedly without allowing the tape to run at all. This slackens the tape and can result in damage.
- do not open the front tape cover. This exposes the tape to fingerprints and dust.

2. Store cassettes . . .

- away from heaters or other heat sources.
- out of direct sunlight.
- where they won't be subject to unnecessary shock or vibration.
- where they won't be exposed to strong magnetic fields (such as those generated by motors, transformers or magnets).
- vertically, in their original cases.



Main Unit

1. For safety, DO NOT . . .

- open the camcorder's chassis.
- disassemble or modify the unit.
- short-circuit the terminals of the battery pack.
Keep it away from metallic objects when not in use.
- allow inflammables, water or metallic objects to enter the unit.
- remove the battery pack or disconnect the power supply while the power is on.
- leave the battery pack attached when the camcorder is not in use.

2. Avoid using the unit . . .

- in places subject to excessive humidity or dust.
- in places subject to soot or steam such as near a cooking stove.
- in places subject to excessive shock or vibration.
- near a television set.
- near appliances generating strong magnetic or electric fields (speakers, broadcasting antennas, etc.).
- in places subject to extremely high (over 40°C) or extremely low (under 0°C) temperatures.

3. DO NOT leave the unit . . .

- in places of over 50°C.
- in places where humidity is extremely low (below 35%) or extremely high (above 80%).
- in direct sunlight.
- in a closed car in summer.
- near a heater.

4. To protect the unit, DO NOT . . .

- allow it to become wet.
- drop the unit or strike it against hard objects.
- subject it to shock or excessive vibration during transportation.
- keep the lens directed at extremely bright objects for long periods.
- direct the eyepiece of the viewfinder at the sun.
- carry it by holding the viewfinder.
- swing it excessively when using the shoulder strap.

5. This camcorder features a built-in head cleaner which automatically cleans the heads and head drum when a cassette is loaded or unloaded. If, however, the heads become dirty and cause blurriness or interruption in the playback picture, consult your nearest JVC dealer.

About moisture condensation . . .

- You have observed that pouring a cold liquid into a glass will cause drops of water to form on the glass' outer surface. This same phenomenon occurs on the head drum of a camcorder when it is moved from a cool place to a warm place, after heating a cold room, under extremely humid conditions or in a place directly subjected to the cool air from an air conditioner.
- Moisture on the head drum can cause severe damage to the video tape, and can lead to internal damage to the camcorder itself.

Serious malfunctioning

If malfunctioning occurs, stop using the unit immediately and consult your local JVC dealer.

For Your Maintenance

1. After Use

- ① Set the power switch to POWER OFF to turn off the camcorder.
- ② Slide EJECT to open the cassette holder, then remove the cassette.
- ③ Close and lock the cassette holder by pressing PUSH.
- ④ Press BATT. RELEASE to remove the battery pack.
- ⑤ Slide the LENS COVER open/close switch to close the lens cover.

2. Cleaning The Camcorder

- ① **CLEAN EXTERIOR**
Wipe gently with a soft cloth.
- ② **CLEAN LENS**
Blow it with a blower brush, then wipe gently with lens cleaning paper.
- ③ **REMOVE EYEPIECE**
Turn the eyepiece counterclockwise and pull it out.
- ④ **CLEAN VIEWFINDER**
Remove dust using a blower brush.
- ⑤ **RE-ATTACH EYEPIECE**
Align the marks, re-attach the eyepiece and turn it clockwise.

NOTES:

- Avoid using strong cleaning agents such as benzine or alcohol.
- Cleaning should be done only after the battery pack has been removed or other power units have been disconnected.
- Mold may form if the lens is left dirty.



TROUBLESHOOTING

EN 47

SYMPTOM	POSSIBLE CAUSE(S)
POWER	
No power is supplied.	<ul style="list-style-type: none"> • The battery pack has not been attached correctly (☞ pg. 4). • The battery pack is not charged (☞ pg. 4). • The power supply has not been correctly connected (☞ pg. 5).
The power suddenly goes off and doesn't come back on by itself.	<ul style="list-style-type: none"> • The battery pack has completely discharged. • Remove the cassette and disconnect the power source, then after a few minutes, try turning the power back on. If it still doesn't come on, consult your nearest JVC dealer.
RECORDING	
Recording cannot be performed.	<ul style="list-style-type: none"> • The recording tape's Erase Protection tab is missing. Cover the hole with adhesive tape. (Some tapes have sliding tabs. In this case, check the position of the tab.)
Recording does not start.	<ul style="list-style-type: none"> • The camcorder Power switch has not been set to "CAMERA" (☞ pg. 12).
PLAYBACK	
The tape is running, but there's no playback picture.	<ul style="list-style-type: none"> • The TV has not been set to its VIDEO mode. • If A/V connection is used, the TV's VIDEO/TV switch has not been set to VIDEO.
Noise bars appear in the playback picture.	<ul style="list-style-type: none"> • Manual Tracking has not been performed (☞ pg. 35).
Playback picture is blurred or interrupted.	<ul style="list-style-type: none"> • The video heads are dirty or worn out. Consult your nearest JVC dealer for head cleaning or replacement.
The counter indication is blurred during Still playback.	<ul style="list-style-type: none"> • This is normal.
TAPE TRANSPORT	
The tape stops during fast-forward or rewind.	<ul style="list-style-type: none"> • The Counter Memory Function has been activated (☞ pg. 35).
Rewinding or fast-forwarding cannot be performed.	<ul style="list-style-type: none"> • The tape is already fully wound on one reel or the other.



SYMPTOM	POSSIBLE CAUSE(S)
OTHER	
The tape won't eject.	<ul style="list-style-type: none"> • The battery pack is running low.
Some functions are not available.	<ul style="list-style-type: none"> • The Shooting Mode selector is set to "FULL AUTO".
Vertical white lines appear when shooting a very bright object.	<ul style="list-style-type: none"> • This sometimes occurs when the contrast between the background and the object is great. It is not a defect of the camcorder.
Bright, crystal-shaped spots appear in the viewfinder.	<ul style="list-style-type: none"> • Sunlight is directly entering the lens.
The picture is blurred in the Quick Review or Retake mode.	<ul style="list-style-type: none"> • The recording speed (SP/LP) has not been properly set (☞ pg. 9).
An error number (E03) appears in the viewfinder.	<ul style="list-style-type: none"> • Turn the camcorder's power off, then disconnect the power source. After a few minutes, try turning the power on again. If the error number still appears in the viewfinder, consult your nearest JVC dealer.
The image is out of focus.	<ul style="list-style-type: none"> • The diopter needs to be adjusted (☞ pg. 6). • The scene being shot is adversely affecting the operation of Auto Focus (☞ pg. 20).
A character generator title and the date and time displays disappear from the viewfinder.	<ul style="list-style-type: none"> • If you remove the power source from the camcorder while the power is on, all settings and selections are erased. Make sure to turn the camcorder's power off before disconnecting the power source.
Even though the Lens Cover is open, the Lens Cover Warning indicator blinks.	<ul style="list-style-type: none"> • The Lens Cover Warning indicator may blink when the camcorder is used in dark areas, regardless of the position of the Lens Cover.

The camcorder is a microcomputer-controlled device. External noise and interference (from a TV, a radio, etc.) might prevent it from functioning properly. In such cases, first disconnect its power supply unit (battery pack, AC Power Adapter/Battery Charger, etc.) and clock battery; and then re-connect it and proceed as usual from the beginning.



SPECIFICATIONS

EN 49

GENERAL

Format	: VHS PAL standard
Power source	: DC 6 V
Power consumption	
light on	: 8.7 W
light off	: 5.7 W
Signal system	: PAL-type
Video recording system	
Luminance	: FM recording
Colour	: Converted sub-carrier direct recording Conforms to VHS standard
Cassette	: cassette
Tape speed	
SP	: 23.39 mm/sec
LP	: 11.70 mm/sec
Recording time Max.	
SP	: 60 minutes (with EC-60 cassette)
LP	: 120 minutes (with EC-60 cassette)
Operating temperature	: 0°C to +40°C
Operating humidity	: 35% to 80%
Storage temperature	: -20°C to +50°C
Weight	: Approx. 810 g
Dimensions	: 109 (W) x 113 (H) x 226 (D) mm

CAMERA

Pick up	: 1/4" format CCD
Lens	: F1.2, f = 4.1 to 57.4 mm, 14:1 power zoom lens with auto iris and macro control, filter diameter 46 mm
Viewfinder	: Electronic viewfinder with 0.5" black/white CRT
White balance adjustment	: Auto/Manual adjustment

VIDEO

Output	: 1 Vp-p, 75 ohms, unbalanced (via VIDEO out connector)
--------	---

AUDIO

Output	: -8 dBs, 1 k-ohm (via AUDIO out connector)
--------	---

AC POWER ADAPTER/BATTERY CHARGER (AA-V11EG)

Power requirement	: AC 110 to 240 V \sim , 50/60 Hz
Power consumption	: 23 W
Output	: DC 8.5 V , 1.3 A (CHARGE), DC 6.3 V , 1.8 A (VTR)
Charging system	: Constant current, peak detection, timer controlled
Dimensions	: 150 (W) x 42 (H) x 68 (D) mm
Weight	: Approx. 350 g

CASSETTE ADAPTER (C-P7U)

Dimensions	: 188 (W) x 25 (H) x 104 (D) mm
Weight	: Approx. 240 g
Accessory	: "R6 (AA)"-size battery x 1

Provided Accessories pg. 3

Optional Accessories

- Battery Packs BN-V12U, BN-V22U, BN-V25U
- Car Battery Charger BH-V3E
- Battery Charger BH-VC10EG
- Car Battery Cord AP-V7E
- Wireless Remote Control Unit RM-V704U
- Compact VHS-C Cassettes EC-60/45/30
- Active Carrying Bag CB-V7U

* Some accessories are not available in some areas. Please consult your nearest JVC dealer for details on accessories and their availability.

*Specifications shown are for SP mode unless otherwise indicated.
E.&O.E. Design and specifications subject to change without notice.*

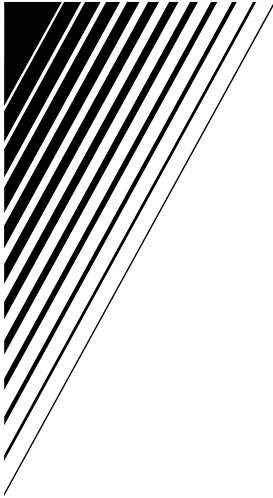

GR-AX760



JVC
VICTOR COMPANY OF JAPAN, LIMITED



COPYRIGHT© 1996 VICTOR COMPANY OF JAPAN, LTD.

EE  Printed in Japan
0396MKV*UN*VP

